



STI-94

- pulse rate / period meter
- rotational / linear speed control
- revolution / movement period control
- 0, 2 or 4 relay / OC outputs
- analogue output: active or passive, power supply output: 24V DC
- RS-485 / Modbus RTU
- "over" signalling when the measuring range is exceeded
- free configuration software S-Config

The STI-94 tachometers are designed to control rotational or linear speed of moving objects. The device is also able to measure frequency. As an additional advantage the device can convert the rotational / linear speed into inverse values, and to display the single revolution period or process duration. The relay / OC control outputs can be programmed depending on the instantaneous value of rotational speed. Additionally the counter may be equipped with analogue outputs, according to the customer selection: active current output, passive isolated current output or active voltage output. The counter can be configured with the local keyboard or free S-Config software via the RS-485 communication port.

TECHNICAL DATA

Power supply	19V ÷ 50V DC; 16V ÷ 35V AC or 85 ÷ 260V AC/DC or 12V AC/DC, all separated
Power consumption	for 12V AC/DC, 85 ÷ 260V AC/DC and 16V ÷ 35V AC power supply: max. 4.5 VA; for 19V ÷ 50V DC: max. 4.5 W
Display	LED, 6 x 13 mm high, red or green (option), brightness adjustable in 8 steps
Inputs	pulse, fully isolated, with debouncing filter and pulse width control, max. input frequency 50.0 kHz
Input levels	low level: 0V ÷ 1 V; high level: 10V ÷ 30V (about 12 mA @ 24V)
Displayed values range	0 ÷ 999999 + decimal point
Rotational speed precision	selected in the range 0 = 0.00000 of unit
Rotational speed unit	revolutions per second (rps), per minute (rpm), per hour (rph)
Pulse waiting time	settable from 0.1 to 39.9 seconds
Accuracy	± 0.02% ± one digit (full temperature range)
Binary outputs	0, 2 or 4 x relay (REL) NO 5A/250V AC (resistance), 3A/250V AC (reactance) or OC I _{max} =30mA, U _{max} =30VDC, P _{max} =100mW
Analogue output (available with 2 x REL or OC, see ordering)	<u>active current</u> : operating range 0/4-20 mA (max. 0-24 mA), load resistance 700 max., resolution 13 bit <u>passive current</u> : isolated, operating range 4-20 mA (max. 2,8-24 mA), load resistance 600 @ 24VDC, resolution 13 bit <u>active voltage</u> : operating range 0/1-5V, 0/2-10V (max. 0-11V), load resistance min. 2000 , resolution 13 bit
Power supply output	24V DC +5%, -10% / max. 100 mA, stabilized
Communication interface	RS-485, 8N1 and 8N2, 1200 bit/s ÷ 115200 bit/s, Modbus RTU (not galvanically isolated)
Operating temperature	0°C ÷ +50°C (standard), -20°C ÷ +50°C (option)
Storage temperature	-10°C ÷ +70°C (standard), -20°C ÷ +70°C (depending on option)
Protection class	IP 65 (front), optional integrated frame for panel cut-out sealing; IP 20 (case and connection dips)
Case	panel mounting; material: NORYL - GFN2S E1
Dimensions	<u>case (WxHxD)</u> : 96 x 48 x 100 mm <u>panel cut-out dimensions</u> : 90.5 x 43 mm <u>installation depth</u> : min. 102 mm <u>board thickness</u> : standard 7 mm or other depending on used board thickness brackets (see Accessories)
Weight	230 g max.

DIMENSIONS

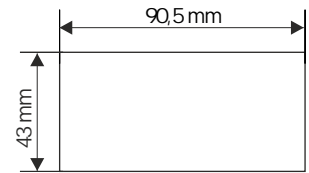
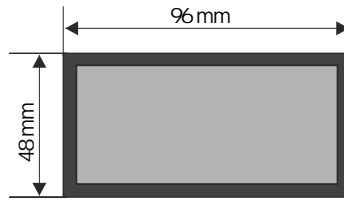
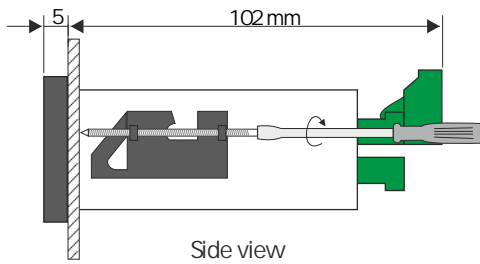

EXAMPLARY PIN ASSIGNMENTS

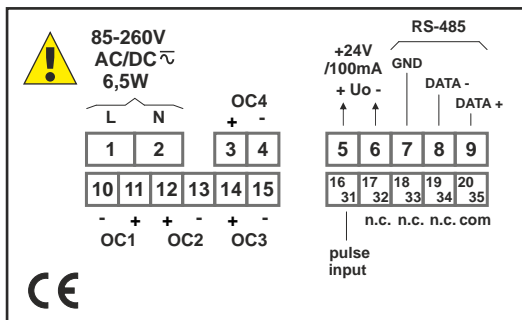
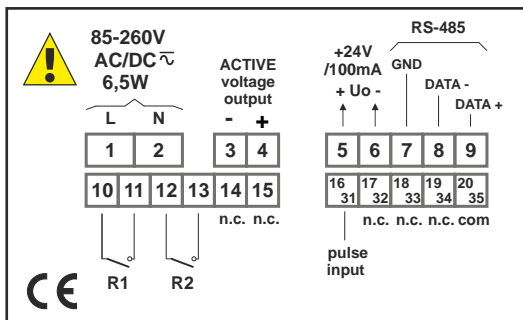
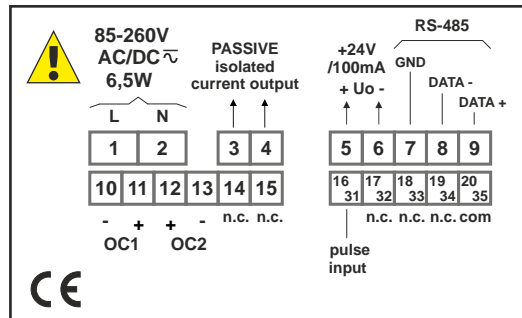
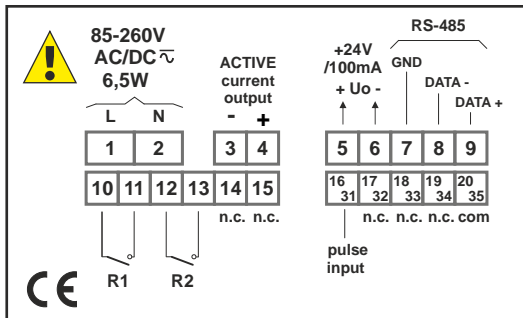

ORDERING

STI-94-14XX-1-X-XX1

type of outputs

- OO: no output
- 21: 2 x REL,
- 22: 2 x OC
- 33: 2 x REL + 1 x AO (0/4-20mA, active, non-isolated)
- 34: 2 x OC + 1 x AO (0/4-20mA, active, non-isolated)
- 39: 2 x REL + 1 x AO (4-20mA, passive, isolated)
- 3A: 2 x OC + 1 x AO (4-20mA, passive, isolated)
- 3B: 2 x REL + 1 x AO (0/1-5V, 0/2-10V, active, non-isolated)
- 3C: 2 x OC + 1 x AO (0/1-5V, 0/2-10V, active, non-isolated)
- 41: 4 x REL,
- 42: 4 x OC

options

- OO: no options
- O1: integrated frame for panel cut-out sealing
- O3: green colour LED display
- O4: integrated frame for panel cut-out sealing + green colour LED display
- O8: operating temp. -20°C ÷ +50°C
- OL: green colour LED display + operating temp. -20°C ÷ +50°C
- OP: integrated frame for panel cut-out sealing + operating temp. -20°C ÷ +50°C
- OT: integrated frame for panel cut-out sealing + green colour LED display + operating temp. -20°C ÷ +50°C

power supply:

- 3: 24V AC/DC
- 4: 85V ÷ 260V AC/DC
- 5: 12V AC/DC



MOUNTING PLATES

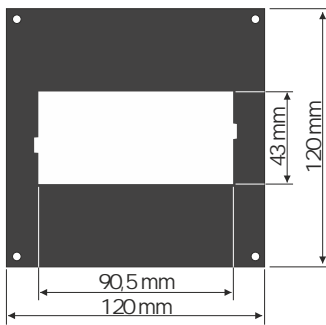

SMP-99/94
to mount 96 x 48 mm
size unit in place
of 96 x 96 mm cut-out

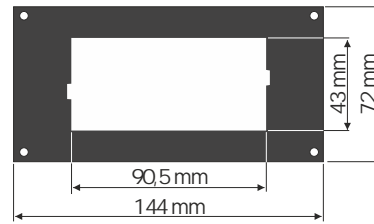

SMP-147/94
to mount 96 x 48 mm
size unit in place
of 144 x 72 mm cut-out

BOARD THICKNESS BRACKETS / ADAPTORS



SPH-07
1 ÷ 7 mm board thickness
brackets (2 pcs)
standard included with device



SPH-45
1 ÷ 45 mm board thickness
brackets (2 pcs)



SPH-05
1 ÷ 5 mm board thickness
brackets (2 pcs)



SRH-94
brackets for mounting devices
on DIN 35/7.5 or 15 rail (2 pcs)

SOFTWARE

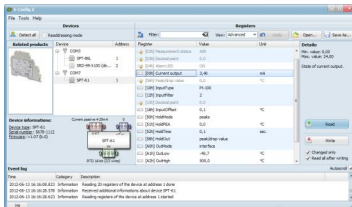

S-Config 2 is used for the simultaneous detection of devices in multiple Modbus RTU networks and allows user to change the configuration of most of them. For each detected device a list of its registers, which the user can modify, is displayed and also additional informations about device parameters (type, address in the network, etc.). S-Config software can be downloaded from SIMEX website at www.simex.pl

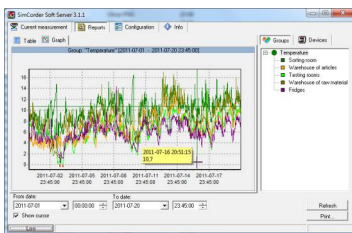

SimCorder Soft is a visualisation application created to facilitate work with advanced networks of the SIMEX devices, for acquisition, visualisation, reporting, archiving, exporting and printing of measurement data from all network devices. You can download measurements from the devices automatically or on demand. There is a possibility of immediate notification about emergency states via SMS or e-mail, which will often allow to quickly resolve an arising problem while avoiding long and expensive stoppages. You can view the measurement data, emergency states and configuration via the internet at every time.

CONVERTERS



The SRS-U4 module is designed to connect a USB host to slave devices equipped with RS-485 interface. The PC with special software can be used as a host. The SRS-U4 unit guarantees full galvanic isolation between USB and RS-485 circuits. The converter can work with any devices equipped with RS-485 interface and contains integrated circuit which supports USB 1.1 and USB 2.0 standards. The main purpose is connection of PC host computer with industrial data acquisition and visualisation systems based on RS-485 interface.

The SRS-U4 can be also manufactured with DIN mounting adaptor.

