

User manual INCLINOMETER SCK-11

- Firmware: v.6.10 or higher
- Measurement of inclinations and acceleration of two orthogonal axes

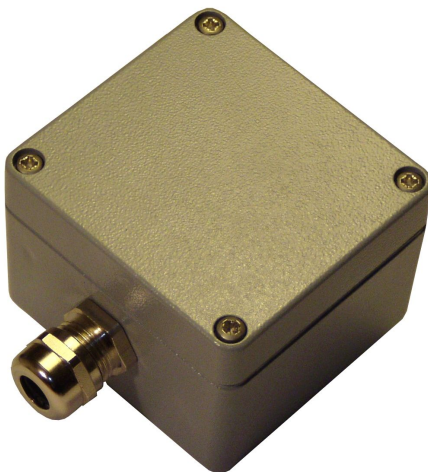

Read the user's manual carefully before starting to use the unit or software.
Producer reserves the right to implement changes without prior notice.

CONTENTS

1. BASIC REQUIREMENTS AND USER SAFETY.....	3
2. GENERAL CHARACTERISTICS.....	3
3. TECHNICAL DATA.....	4
4. DEVICE INSTALLATION.....	5
4.1. UNPACKING.....	6
4.2. ASSEMBLY.....	6
4.3. CONNECTION METHOD.....	7
4.4. MAINTENANCE.....	11
5. PRINCIPLE OF OPERATION.....	12
6. THE MODBUS PROTOCOL HANDLING.....	12
6.1. LIST OF REGISTERS.....	13
6.2. TRANSMISSION ERRORS DESCRIPTION.....	16
6.3. EXAMPLES OF QUERY/ANSWER FRAMES.....	17
7. FORCING OF ADDRESS FFH.....	19

Explanation of symbols used in the manual:



- This symbol denotes especially important guidelines concerning the installation and operation of the device. Not complying with the guidelines denoted by this symbol may cause an accident, damage or equipment destruction.

IF THE DEVICE IS NOT USED ACCORDING TO THE MANUAL THE USER IS RESPONSIBLE FOR POSSIBLE DAMAGES.



- This symbol denotes especially important characteristics of the unit.
Read any information regarding this symbol carefully

1. BASIC REQUIREMENTS AND USER SAFETY



- **The manufacturer is not responsible for any damages caused by inappropriate installation, not maintaining the proper environmental conditions and using the unit contrary to its assignment.**
- Installation should be conducted by qualified personnel . During installation all available safety requirements should be considered. The fitter is responsible for executing the installation according to this manual, local safety and EMC regulations.
- The unit must be properly set-up, according to the application. Incorrect configuration can cause defective operation, which can lead to unit damage or an accident.
- **If in the case of a unit malfunction there is a risk of a serious threat to the safety of people or property additional, independent systems and solutions to prevent such a threat must be used.**
- **The unit uses dangerous voltage that can cause a lethal accident. The unit must be switched off and disconnected from the power supply prior to starting installation of troubleshooting (in the case of malfunction).**
- Neighbouring and connected equipment must meet the appropriate standards and regulations concerning safety and be equipped with adequate overvoltage and interference filters.
- **Do not attempt to disassemble, repair or modify the unit yourself. The unit has no user serviceable parts. Units, in which a defect was stated must be disconnected and submitted for repairs at an authorized service centre.**



- Do not use the unit in areas threatened with excessive shocks, vibrations, dust, humidity, corrosive gasses and oils.
- Do not use the unit in areas where there is risk of explosions.
- Make sure that the ambient temperature (e.g. inside the control box) does not exceed the recommended values. In such cases forced cooling of the unit must be considered (e.g. by using a ventilator).



The unit is designed for operation in an industrial environment and must not be used in a household environment or similar.

2. GENERAL CHARACTERISTICS

The dual axis inclinometer module **SCK-11** was designed to stationary measurements of inclinations of two orthogonal axes in rotation to earth. Recommended range of measured angles maintains -70 to +70 degrees (in relation to earth). While measuring in range -20 to +20 degrees range, the precision is better than 0.1 deg in both axes. If measured angles exceeds range ± 75 deg (in relation to earth) the measurement error can be higher 3 deg (at both ends of range). Due storing of new scaling values to internal registers it is possible to

change measurement unit and resolution to any other linear. Build in offset registers allows user to measure relative angles, and self zeroing after mounting.

In addition to two registers containing information about **SCK-11** installation plane angle relative to the earth (two angles with the offset function), there are available additional two records containing information on the accelerations in the same axes, what makes measurement of transducer movement more precision. Indications of these records are expressed in 1/1000 of earth gravity, which corresponds to the reading equal to 1000 when inclination of sensor equals 90 degrees in relation to earth.

Additional temperature measurement circuit allows to check temperature of internal accelerometer and compensate the measurements. Internal temperature can be read by user as third measurement channel.

Substantial aluminium case with high IP rating, wide operation temperature range (-40°C to +80°C), and temperature compensation circuit allows to use **SCK-11** outside of buildings, with hard environment conditions (containers, platforms, outriggers, jibs etc.). The device should not be used while strong vibrations occurs, and must not be used for security systems.

SCK-11 is equipped with RS-485 communication interface with Modbus RTU protocol, allowing direct readings of measurements and full configuration of the device.

3. TECHNICAL DATA

Power supply voltage	10... 24 ...36V DC (not separated)
Current consumption	during operation - typically 12 mA @ 24V DC during Modbus transmission - up to 60 mA
Angle detector	MEMS
Axes	2
Recommended maximum angle measurement range	±70° in relation to earth
Inclination measurement unit	any, factory scaled to degrees
Inclination measurement resolution	0,001 to 1, user configured
Inclination measurement error	In range ±30° : < 0,2%, max. ±0,05° @ 25°C In range ±70° : < 0,5%, max. ±0,2° @ 25°C
Inclination measurement nonlinearity	±0,1%
Recommended maximum gravity measurement range	±1,5G (1G = gravitational acceleration of earth)
Acceleration unit	0,001 G
Acceleration resolution	0,001 G
Temperature compensation	-40°C to +85°C
Max frequency	10 Hz
Communication interface	RS 485, 8N1 / Modbus RTU, not separated
Baud rate	1200 bit/s ÷ 115200 bit/s

Protection level	IP 67
Housing type	wall mounted
Housing material	aluminium
Housing dimensions	
without glands	75 x 80 x 57 mm
with glands	100 x 80 x 57 mm
Weight	350 g
Operation temperature	
Allowable	-40°C do +85°C
Recommended	-30°C do +60°C
Storage temperature	-40°C do +85°C
Altitude	up to 2000 meters above sea level
Fastening	to wall, 2 M3 bolts
Connection cable	4 conductors (2 supply conductors + 2 data transmission conductors) shielded; recommended: UNITRONIC - FD® CP (TP) plus
Screws tightening max. torque	0,5 Nm
Max. connection leads diameter	2,5 mm ²
EMC	PN-EN 61326-1



Measurement errors was determined while static measurements in both axes, at temperature 25°C and maximum measurement filtration enabled (internal digital filters). To minimize influence of electromagnetic noise please refer to notices included in chapter **CONNECTION METHOD**. Due to strong mechanical stress in elements on which the device is mounted the measurements can slightly fluctuate.



This is a class A unit. In housing or a similar area it can cause radio frequency interference. In such cases the user can be requested to use appropriate preventive measures.

4. DEVICE INSTALLATION

The unit has been designed and manufactured in a way assuring a high level of user safety and resistance to interference occurring in a typical industrial environment. In order to take full advantage of these characteristics installation of the unit must be conducted correctly and according to the local regulations.



- Installation should be conducted by qualified personnel.
- Read the basic safety requirements on page 3 prior to starting the installation.
- All installation works must be conducted with a disconnected power supply.

4.1. UNPACKING

After removing the unit from the protective packaging, check for transportation damage. Any transportation damage must be immediately reported to the carrier. Also, write down the unit serial number on the housing and report the damage to the manufacturer.

Attached with the unit please find:

- warranty,
- user's manual for **SCK-11** unit (device)

4.2. ASSEMBLY



- Disconnect the power supply prior to starting assembly.
- Check the correctness of the performed connections prior to switching the unit on.

To install the device prepare pinholes accordingly to Figure 4.1. Back side of the case (with mounting holes) should be mounted using screws.

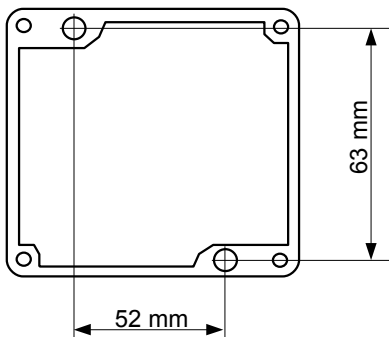

Figure 4.1. Distances between pinholes



The device should not be used while strong vibrations occurs, and must not be used for security systems.

4.3. CONNECTION METHOD

Caution



- Installation should be conducted by qualified personnel . During installation all available safety requirements should be considered. The fitter is responsible for executing the installation according to this manual, local safety and EMC regulations.

This device is not fully isolated. Pay special attention to installation method, while the device is installed outside. User should use proper measures, guarantee safety while storm lighting e.g. safety equipment like: separators, isolators etc. Due to metal housing the risk of electric shock occurs. To avoid of accidents additional PE connection should be made between the device and the rest of construction details.

- Wiring must meet appropriate standards and local regulations and laws.
- Tighten the clamping screws. The recommended tightening torque is 0.5 Nm. Loose screws can cause fire or defective operation. Over tightening can lead to damaging the connections inside the units and breaking the thread.
- The unit is equipped with housing, covers and sealing packing, protecting against water intrusion, pay special attention to their correct tightening or clamping. In the case of any doubt consider using additional preventive measures (covers, roofing, seals, etc.). Carelessly executed assembly can increase the risk of electric shock.

Due to possible significant interference in industrial installations appropriate measures assuring correct operation of the unit must be applied. To avoid the unit of improper indications keep recommendations listed below.

- Avoid common (parallel) leading of signal cables and transmission cables together with power supply cables and cables controlling induction loads (e.g. contactors). Such cables should cross at a right angle.
- Contactor coils and induction loads should be equipped with anti-interference protection systems, e.g. RC-type.
- Use of screened signal cables is recommended. Signal cable screens should be connected to the earthing only at one of the ends of the screened cable.
- In the case of magnetically induced interference the use of twisted couples of signal cables (so-called “spirals”) is recommended. The spiral (best if shielded) must be used with RS-485 serial transmission connections.
- In the case of interference from the power supply side the use of appropriate anti-interference filters is recommended. Bear in mind that the connection between the filter and the unit should be as short as possible and the metal housing of the filter must be connected to the earthing with largest possible surface. The cables connected to the filter output must not run in parallel with cables with interference (e.g. circuits controlling relays or contactors).

Use cables 2x2x0.5 (double twisted pair with the shield) with **round cross-section**, and circumference about 0.5 mm per wire, for connection of the device. Recommended cable type is: UNITRONIC - FD® CP (TP) plus, it has suitable strange to hard environment conditions.

Recommended method of wire preparation and connection of the device.

1. Preparation of the wire: Remove outer insulation of the wire at about 55 mm (Figure 4.2). Roll the shield, and put it into the isolation pipe (or a tape), next crimp the terminal. On the rest of the outer isolation make an incision about 15 mm from the edge.

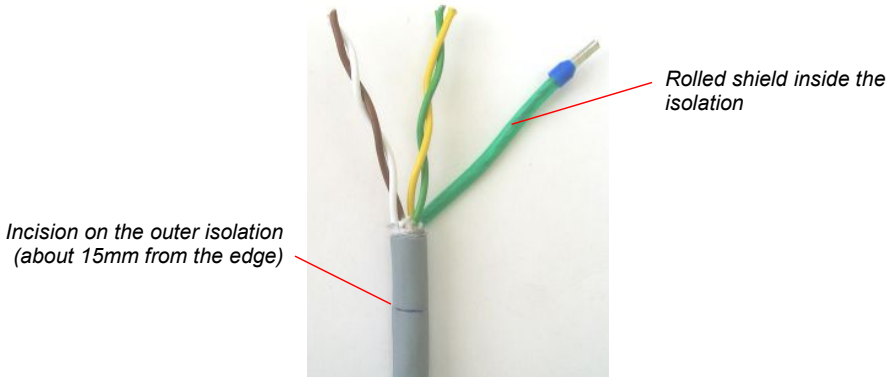
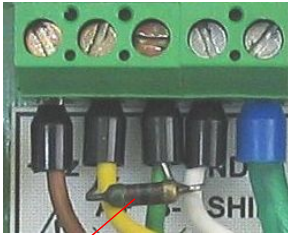

Figure 4.2. Preparation of the wire

2. The uninsulated end of the wire put into the gland (Figure 4.3). The ends of the wires should be uninsulated and crimped. If the device is the last module of the RS-485 bus, the ending terminal (resistor 100Ω) should be crimped together with the ends of wires. (Figure 4.3). One pair of the wires connect to RS-485 bus terminals, and other to the power supply terminals. After that slide outer isolation a little to expose the shield on about 5 mm (Figure 4.3).



The termination resistor (100Ω) crimped together with ends of the bus wires



Exposed part of the shield

Figure 4.3. Connection

3. Move the exposed part of the shield into the gland (pulling the other end of the wire), to ensure good electrical contact with the housing via springs inside the gland (Figure 4.4, 4.5). Put special attention to ensure that outer isolation (but not exposed shield) was under the o-ring seal inside the gland. (Fig 4.5).



Figure 4.4. Properly made connection

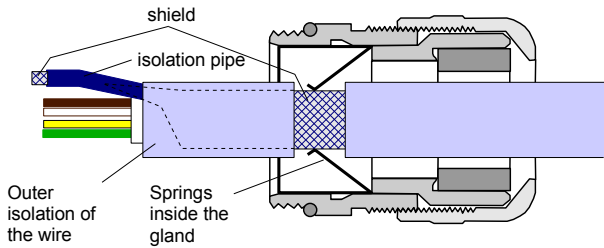

Figure 4.5. Properly made connection of the shield and the springs inside the gland.

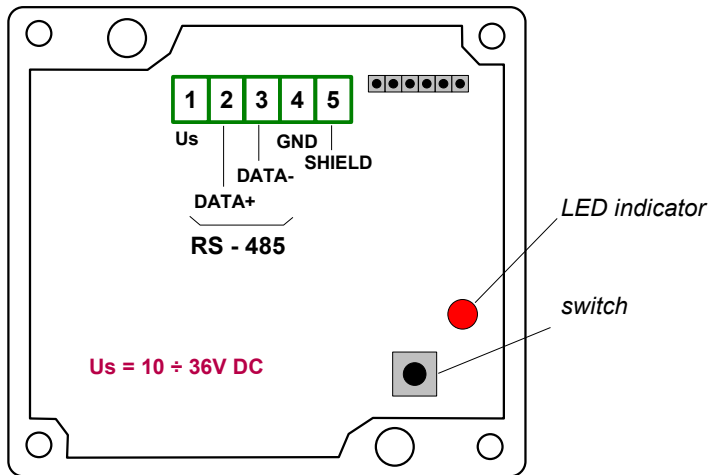
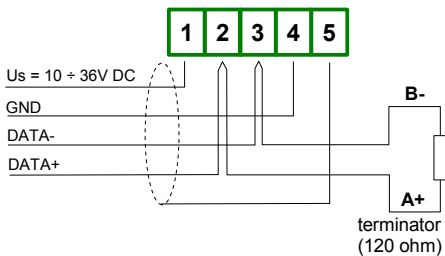

Figure 4.6. Location of elements inside the module case



Last module of the network must be terminated with 100÷150 Ohm resistor .

Figure 4.7. Connection of the module to the network

An example of the transducers application is multipoint monitoring system (Figure 4.5). Control panel (i.e. SPA-99 made by SIMEX) is used as MASTER in MODBUS network, simultaneously it displays read informations of all measurement points.

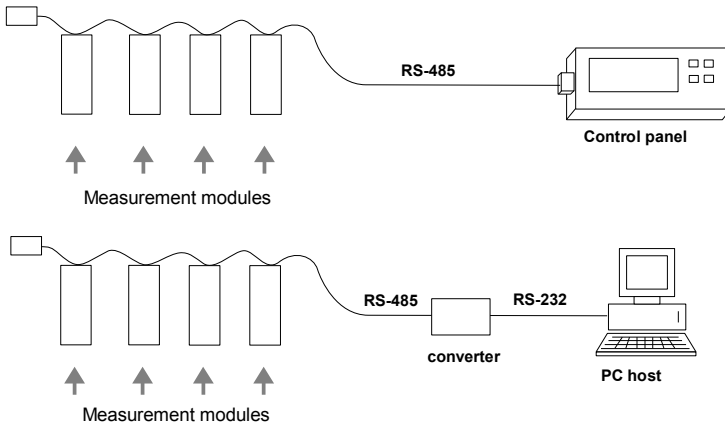

RS-485 bus should be equipped with termination resistors (100-150 ohm) on both ends. The bus must not be ramified, and longer than 1 km.

Figure 4.8. Example application of the transducers

4.4. MAINTENANCE

The unit does not have any internal replaceable or adjustable components available to the user. Pay attention to the ambient temperature in the room where the unit is operating. Excessively high temperatures cause faster ageing of the internal components and shorten the fault-free time of unit operation.

In cases where the unit gets dirty do not clean with solvents. For cleaning use warm water with small amount of detergent or in the case of more significant contamination ethyl or isopropyl alcohol.



Using any other agents can cause permanent damage to the housing.



Product marked with this symbol should not be placed in municipal waste. Please check local regulations for disposal and electronic products.

5. PRINCIPLE OF OPERATION

The module is equipped with integrated angle detector in MEMS structure. It processes its own position in relation to gravitation vector (in two orthogonal axes) to electrical signals, digitized and recalculated by microcontroller. At the same time the measurement of MEMS temperature is made, and its result is used to compensate the angle measurements (every module is individually calibrated while production). The compensated angle is then recalculated due to scale coefficients. Scale coefficient is equal to right angle in desired unit. The resolution of the measurement is always equal to selected by user decimal point position. Factory settings are: scale 90 degrees, decimal point position set to 2 in both axes. Such settings allows to measure angle in resolution of 0.01 degree, and gives results in range -9000 to +9000. Writing value 100 to „scale register” it is possible to obtain measurements in grades, with resolution of 0.01 (results in range -10000 to +10000). Storing value 1570 to „scale register”, and 0 to „decimal point position” it is possible to obtain the result in radians (to be exact milliradians). Theoretical result at right angle will then be 1570 (1.57 rad), so the resolution of the measurement will be 0.001 rad. Changing the scale register, special attention must be paid to decimal point position settings. Set this registers to ensure that expected results could be stored in two bytes (single register), and set them to simplify interpretation of the result.

Additional offset registers allow to make relative measurements to selected zero point, and correction of installation shifts. Remember, measurements are always made in relation to earth (and recalculated with offset registers) and mentioned precision and measurements errors are related to angles in relation to the ground. Pay special attention on this fact while measurements. Offset registers values are not recalculated due to scale and decimal point, so they must be reset after scale changing. To simplify relative measurements firmware has special procedures to set offset registers at selected zero point (independent in both axes).

Any MASTER controller (i.e. Control panel or PC) can read the data from the **SCK-11** module. Every module has factory set address **FEh**. It can be changed via RS-485 interface or manually by pressing the internal switch (see: **FORCING OF ADDRESS FFh**). All settings and calibration data stored into internal EEPROM are available via RS-485 interface under fixed register numbers. It is prohibited to change any calibration registers of the device, under the restriction of guaranty loss of the warranty.

LED indicator is installed in the module mainboard, it indicates following situations:

- normal operation mode - flashes every about 1 second
- handmade forcing of address **FFh** and baud rate **9600 bit/sec.** - permanent light

6. THE MODBUS PROTOCOL HANDLING

Transmission parameters:	1 start bit, 8 data bits, 1 stop bit, no parity control
Baud rate:	selectable from: 1200 to 115200 bits/second
Transmission protocol:	MODBUS RTU compatible

The device parameters and measurement result are available via RS-485 interface, as HOLDING-type registers of Modbus RTU protocol. The registers (or groups of the registers) can be read by 03h function, and wrote by 06h (single registers) or 10h (group of the registers) accordingly to Modbus RTU specification. Maximum group size for 03h and 10h functions can not exceeds 5 registers (for single frame).

The device interprets the broadcast messages, but then do not sends the answers.

6.1. LIST OF REGISTERS

All values are represent in hexadecimal.

Register	Write	Range	Register description
01h ¹	No	see descr.	X axis angle result. This register contains relative angle of X axis, dependent on X scale register (reg. 34h) and decimal point position (reg. 32h), for factory settings range of this register is ± 9000 , and represents angles of ± 90 with resolution 0.01°
02h ¹	No	see descr.	Y axis angle result. This register contains relative angle of Y axis, dependent on Y scale register (reg. 35h) and decimal point position (reg. 33h), for factory settings range of this register is ± 9000 , and represents angles of ± 90 with resolution 0.01°
03h	No	see descr.	Higher byte: status of X axis measurement Lower byte: status of Y axis measurement 00h – no errors 40h – underflow error, measured value lower than smallest allowed value. 80h – overflow error, measured value higher than highest allowed value.
04h	Yes	see descr.	Higher byte: decimal point position of X axis Lower byte: decimal point position of Y axis Every byte can get value $0 \div 3$. The content of this register is a cumulated copy of registers 32h and 33h – and all notices for these registers are important to register 04h Factory settings: 0202h
05h	No	see descr.	Temperature of internal accelerometer. Temperature expressed in one tenth of Celsius degree e.g.: value 253 means 25.3°C .
06h	No	see descr.	Status of temperature sensor: Higher byte - hardware status: 0x00 – no hardware errors 0xFE – shortcut of data line Vcc or GND 0xFF – sensor not detected Lower byte - data status. 0x00 – no measurement errors 0x01 – unknown error 0x02 – sensor initialisation error 0x03 – CRC error
08h \div 0Fh	No	see descr.	Calibration error (read only)
11h	No	-1500 \div 1500	X axis acceleration
12h	No	-1500 \div 1500	Y axis acceleration
20h ²	Yes	0 \div 199	Modbus Address. Factory settings = FEh

Register	Write	Range	Register description
21h	No	2071h	ID of the device
22h ³	Yes	0 ÷ 7	Baud rate 0 - 1200 bit/sec.; 1 - 2400 bit/sec.; 2 - 4800 bit/sec.; 3 - 9600 bit/sec.; 4 - 19200 bit/sec.; 5 - 38400 bit/sec.; 6 - 57600 bit/sec.; 7 - 115200 bit/sec. Factory settings 3 (9600 bit/sec)
23h ⁴	Yes	0 ÷ 1	Permission to write registers via RS-485 interface: 0 - write denied ; 1 - write allowed
30h	Yes	0 ÷ 5	Measurement filter of X axis The value of the filter determines the rate of data filtration. Filtration is realised by exponential digital filter. Value 0 turns off the filter, and value 5 maximum filtration. Warning: While maximum filtration is enabled results of measurements are much slowly updated, therefore selection of filter rate must be done very carefully, due to the use of the device. Factory settings 0.
31h	Yes	0 ÷ 5	Measurement filter of Y axis. See notices above
32h	Yes	0 ÷ 3	Decimal point position of angle measurement of X axis. This register has influence on obtained resolution in the X axis. If value 0 is stored to this register, it causes that for right angle theoretical value of X axis result would be equal to the scale register of X axis (reg. 34h – factory set to 90). Storing 1 to register 32h causes multiplication of obtained values by 10, 2 causes multiplication by 100, and 3 by 1000. Pay attention that obtained angle result (reg. 01h) is represented by 2 byte value, and its range must be selected properly. While scale is set to 90, and decimal point to 3, theoretical maximum result would get 90000 and that value cant be represented by 2 bytes (single register). Factory settings 2.
33h	Yes	0 ÷ 3	Decimal point position of angle measurement of Y axis. See notices above
34h	Yes	0 ÷ FFFFh	Angle measurement scale of X axis. This register defines theoretical result (extended by decimal point register) while right angle in relation to the earth in X axis occurs. Factory settings of this register equals 90, what causes measurements in degrees. Factory setting of decimal point (2) allows to obtain resolution of 0.01 degree in angle X register (reg. 01h), Factory settings 90.
35h	Yes	0 ÷ FFFFh	Angle measurement scale of Y axis. See notices above

Register	Write	Range	Register description
36h	Yes	-1000 ÷ 1000	<p>Angle measurement offset of X axis.</p> <p>Value of this register is subtracted from currently recalculated angle of X axis (due to scale and decimal points registers), and the result is available as X angle in register 01h. The use of this register allows simply correction of assembly shifts, and relative measurements. Remember that precision of measurement depends on angle in relation to earth (not to offset, and result registers).</p> <p>The value of this register is not rescaled after change of the scale and decimal point position, and must be reset (or zeroed) after these operations. Factory settings 0.</p>
37h	Yes	-1000 ÷ 1000	Angle measurement offset of Y axis. See notices above
38h	Yes	-100 ÷ 100	acceleration offset of X axis.
39h	Yes	-100 ÷ 100	acceleration offset of Y axis.
3Fh	Yes	0 ÷ 2	<p>Measurement rate:</p> <p>0 - up to 4 measurements / sec. per each channel (default)</p> <p>1 - up to 7 measurements / sec. per each channel</p> <p>2 - up to 15 measurements / sec. per each channel</p> <p>Warning: Increasing of measurement rate causes increasing of measurement noises (proportionally to measurement rate value).</p>
40h ÷ 47h	-	see descr.	<p>Calibration registers</p> <p>Do not modify this registers !</p> <p>It is prohibited to change any calibration registers of the device, under the restriction of guaranty loss of the warranty.</p>
0FFF0h 0FFF1h	No	see descr.	Serial number of the device
0FFF2h	No	2071h	ID of the device
0FFF3h	No	see descr.	Software version
0FFF4h	No	see descr.	Compilation version

Register	Write	Range	Register description
0FFFFh	Tak	0601h, 0602h, 0603h, 0611h, 0612h, 0613h	<p>Special functions register.</p> <p>This register allows user to make some automatic build in operation of the device. Before writing this register it is required to initialise execution of functions by doing 3 following writes:</p> <p>value 0x5465 into 0xFFFFD register, value 0xDDDD into 0xFFFE register, value 0x8000 into 0xFFFF register.</p> <p>For user it is one function available:</p> <p>06h – self-offsetting. The device stores calculated angle of X and Y axes into offset registers, and set actual position as „zero point”</p> <p>Clear offset registers before self-offsetting.</p> <p>The number of the function should be written to higher byte of the register, and number of the channel to the lower byte:</p> <p>01h - angle channel of X axis, 02h - angle channel of Y axis, 03h - both angle channels, 11h - acceleration channel of X axis, 12h - acceleration channel of Y axis 13h - both acceleration channels.</p> <p>WARNING: Do not try other function codes, because it may cause by destroying of factory calibration settings and and loss of warranty.</p>

- 1 - the module conserves its precision in measurement range showed in technical data
- 2 - after writing to register no 20h the device responds with an “old” address in the message.
- 3 - after writing to register no 22h the device responds with the new baud rate.
- 4 - the value of the register 23h is also connected to write to this register, so it is possible to block a writes, but impossible to unblock writes via RS-485 interface, The unblocking of the writes is possible by “**Forcing of FFh address**” procedure only.

6.2. TRANSMISSION ERRORS DESCRIPTION

If an error occurs while write or read of single register, then the device sends an error code according to Modbus RTU specifications.

Angle measurement error codes:

- 00h - no errors (apply to status register only).
- 80h - measured value higher than highest allowed value
- 40h - measured value lower than smallest allowed value

Measurements errors in this register are the results of measurement accuracy, badly made calibration or modifications of calibration registers.

Temperature measurement error codes:

00h - no errors (apply to status register only).

01h - unknown error (apply to lower byte of status register only)

02h - sensor initialisation error (apply to lower byte of status register only)

03h - CRC error (apply to lower byte of status register only)

FEh - shortcut of data line Vcc or GND (apply to higher byte of status register only)

FFh - sensor not detected (apply to higher byte of status register only)



Error code can be a logical sum of two or more errors. Sensor failure usually do not breaks actualisation of measurement results, and current result can be read using multi register mode (in single register mode the modules send off the exception codes).

6.3. EXAMPLES OF QUERY/ANSWER FRAMES

Examples apply for device with address 1. All values are represent hexadecimal.

Field description:

ADDR Device address on modbus network

FUNC Function code

REG H,L Starting address (address of first register to read/write, Hi and Lo byte)

COUNT H,L No. of registers to read/write (Hi and Lo byte)

BYTE C Data byte count in answer frame

DATA H,L Data byte (Hi and Lo byte)

CRC L,H CRC error check (Hi and Lo byte)

Example 1. The frame contains the query of X angle (scale 90°+ 2 places after decimal point) to the device **SCK-11** with address 1 (single register query)

ADDR	FUNC	REG H,L		COUNT H,L		CRC L,H	
01	03	00	01	00	01	D5	CA

a) Answer of the device (no errors)

ADDR	FUNC	BYTE C	DATA H,L		CRC L,H	
01	03	02	00	FF	F8	04

DATA H,L - result expressed in 0.01° units (in this case 2.55°)

b) The answer (if an error occurs):

ADDR	FUNC	ERROR	CRC L,H	
01	83	40	40	C0

ERROR - error code (it means angle smaller than -90°)

Example 2. Read of ID code

ADDR	FUNC	REG H,L		COUNT H,L		CRC L,H	
01	03	00	21	00	01	D4	00

The answer:

ADDR	FUNC	BYTE C	DATA H,L		CRC L,H	
01	03	02	20	71	61	A0

DATA L - identification code (2071h)

Example 3. Change of the device address from 1 to 2 (write to reg. 20h)

ADDR	FUNC	REG H,L		COUNT H,L		CRC L,H	
01	06	00	20	00	02	09	C1

DATA H - 0

DATA L - nowy adres (2)

The answer (the same as the message):

ADDR	FUNC	REG H,L		COUNT H,L		CRC L,H	
01	06	00	20	00	02	09	C1

Example 4. Multiregister query , starting register 01h, number of registers to read 2

ADDR	FUNC	REG H,L		COUNT H,L		CRC L,H	
01	03	00	01	00	02	95	CB

The answer:

If proper angle measurements of both axes (X and Y) are done (both scales: 90°+ 2 places after decimal point)

ADDR	FUNC	BYTE C	REG 01		REG 02		CRC L,H	
01	03	04	00	C1	0A	5A	2D	54

Interpretation of the answer:

- X angle 00C1h = 193, means 1.93°

- Y angle 0A5Ah = 2650, means 26.50°



There is no full implementation of the Modbus Protocol in the device. The functions presented above are available only.

7. FORCING OF ADDRESS FFH

New devices has set to Modbus addresses **0xFE**. To enhance system installation (or re-installation, while actual address of the device is unknown) process special operation mode has been developed. It allows to force special address (for this device it is **0xFF**) in single module using internal momentary switch mounted on module mainboard (Figure 4.2). Additionally this process forces baud rate to default value **9600** bit/sec.

To force address of device to this **special value**, turn module power supply and wait until it's LED indicator flashes every 1 second. Next press internal switch button and hold it at least 4 seconds. While button is being pressed LED indicator is turned off until readdressing. After about 4 seconds LED indicator start to light permanently – it is signal that module address has been changed to special value (in this case **0xFF**) – then release switch. At this moment MASTER controller should find new device and readdress it (it is recommended to set address different than **0xFF** and **0xFE**). After remote readdressing LED indicator is being turned off, and starts to flashes again.

Change of the device address from FEh to 01h:

ADDR	FUNC	REG H,L		COUNT H,L		CRC L,H	
FE	06	00	20	00	01	5D	CF

The answer is the same as the message.

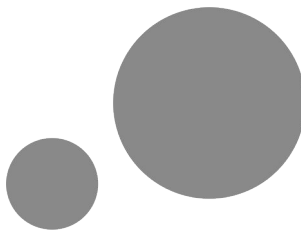

SIMEX Sp. z o.o.
ul. Wielopole 7
80-556 Gdańsk
Poland

tel.: (+48 58) 762-07-77
fax: (+48 58) 762-07-70

<http://www.simex.pl>
e-mail: info@simex.pl