

User manual COUNTER SLE-73

- Firmware: v.4.00 or higher
- Input type: pulse
- Low-cost counter



Read the user's manual carefully before starting to use the unit or software.
Producer reserves the right to implement changes without prior notice.

CONTENTS

1. BASIC REQUIREMENTS AND USER SAFETY.....	3
2. GENERAL CHARACTERISTICS.....	4
3. TECHNICAL DATA.....	4
4. DEVICE INSTALLATION.....	5
4.1. UNPACKING.....	6
4.2. ASSEMBLY.....	6
4.3. CONNECTION METHOD.....	8
4.4. MAINTENANCE.....	11
5. FRONT PANEL DESCRIPTION.....	12
6. PRINCIPLE OF OPERATION.....	12
6.1. MEASUREMENT MODE.....	12
6.2. THE DIGITAL FILTER.....	13
7. DEVICE PROGRAMMING.....	14
7.1. PROGRAMMING MENU.....	14
7.2. PARAMETERS EDITION.....	15
7.2.1. Numeric parameters (digit change mode).....	15
7.2.2. Numeric parameters (slide change mode).....	15
7.2.3. Switch parameters ("LIST" type).....	16
7.3. MENU DESCRIPTION.....	16
7.3.1. "rESEt" parameter.....	17
7.3.2. "FiltEr" parameter.....	17
7.3.3. "Pr inP" parameter.....	17
7.3.4. "PrESCA" menu.....	18
7.3.5. "rS-485" menu.....	18
7.3.6. "SEtcod" parameter.....	20
7.3.7. "briGHt" parameter.....	20
7.3.8. "Edit" parameter.....	20
7.3.9. "dEFS" parameter.....	20
7.4. MENU STRUCTURE.....	21
8. EXAMPLES OF PRESCALER PARAMETERS CALCULATION.....	22
9. THE MODBUS PROTOCOL HANDLING.....	22
9.1. LIST OF REGISTERS.....	23
9.2. TRANSMISSION ERRORS DESCRIPTION.....	24
9.3. EXAMPLES OF QUERY/ANSWER FRAMES.....	25
10. DEFAULT AND USER'S SETTINGS LIST.....	28

Explanation of symbols used in the manual:



- This symbol denotes especially important guidelines concerning the installation and operation of the device. Not complying with the guidelines denoted by this symbol may cause an accident, damage or equipment destruction.

IF THE DEVICE IS NOT USED ACCORDING TO THE MANUAL THE USER IS RESPONSIBLE FOR POSSIBLE DAMAGES.



- This symbol denotes especially important characteristics of the unit. Read any information regarding this symbol carefully

1. BASIC REQUIREMENTS AND USER SAFETY



- **The manufacturer is not responsible for any damages caused by inappropriate installation, not maintaining the proper environmental conditions and using the unit contrary to its assignment.**
- Installation should be conducted by qualified personnel . During installation all available safety requirements should be considered. The fitter is responsible for executing the installation according to this manual, local safety and EMC regulations.
- The unit must be properly set-up, according to the application. Incorrect configuration can cause defective operation, which can lead to unit damage or an accident.
- **If in the case of a unit malfunction there is a risk of a serious threat to the safety of people or property additional, independent systems and solutions to prevent such a threat must be used.**
- **The unit uses dangerous voltage that can cause a lethal accident. The unit must be switched off and disconnected from the power supply prior to starting installation of troubleshooting (in the case of malfunction).**
- Neighbouring and connected equipment must meet the appropriate standards and regulations concerning safety and be equipped with adequate overvoltage and interference filters.
- **Do not attempt to disassemble, repair or modify the unit yourself. The unit has no user serviceable parts. Defective units must be disconnected and submitted for repairs at an authorized service centre.**



- In order to minimize fire or electric shock hazard, the unit must be protected against atmospheric precipitation and excessive humidity.
- Do not use the unit in areas threatened with excessive shocks, vibrations, dust, humidity, corrosive gasses and oils.
- Do not use the unit in areas where there is risk of explosions.
- Do not use the unit in areas with significant temperature variations, exposure to condensation or ice.
- Do not use the unit in areas exposed to direct sunlight.
- Make sure that the ambient temperature (e.g. inside the control box) does not exceed the recommended values. In such cases forced cooling of the unit must be considered (e.g. by using a ventilator).



The unit is designed for operation in an industrial environment and must not be used in a household environment or similar.

2. GENERAL CHARACTERISTICS

The economical pulse counter type **SLE-73** has been build as simplified version of SIMpact series digital counters. It is designed for up-down counting in range of 6 digits. This low cost counter is equipped with single counting input, the maximum frequency of input signal is limited to 3 kHz. Additional programmable input allows to clear counter's value, hold counting or change counting direction (one of them). The inputs are fully separated from other internal circuits. **SLE-73** can cooperate with electronic and mechanical sensors. Build in adjustable digital filter allows denouncing of mechanical contacts. The six digits display, can display decimal point on any position (user defined). Internal input divider can be programmed to value from 1 to 999999, and together with programmable multiplier and decimal point realize recalculation of input pulses to desired units. The counter can be manually zeroed using **[RESET]** button. Zeroing can be done at any time, but needs confirmation by **[ENTER]** button. Using local keyboard user can change all parameters as wish, and access to settings (menu) can be protected by 4-digit, user defined password.

Thanks to small dimensions (72 x 36 mm) **SLE-73** can be used in any place where the space is limited.

3. TECHNICAL DATA

Power supply voltage (depending on version)	85... 230 ...260V AC/DC; 50 ÷ 60 Hz (separated)
External fuse (required)	or 19... 24 ...50V DC and 16... 24 ...35V AC (separated)
Power consumption	T - type, max. 2 A max. 4,5 VA @ 85 ÷ 260V AC/DC max. 4,5 VA @ 16V ÷ 35V AC max. 4,5 W @ 19V ÷ 50V DC
Pulse inputs	
B input	counting (PNP, terminal no. 7)
C input	programmable (PNP, terminal no. 8)
COM	common terminal (terminal no. 9)
Input levels	
low level:	0V ÷ 1V
high level:	10V ÷ 30V (12 mA @ 24V)
Max. input frequency	electronic: 3 kHz contact: 90 Hz (adjustable filter)
Display range	-99999 ÷ 999999, plus decimal point
Sensor supply output:	24V +5%, -10% / max. 100 mA, stabilized
Communication interface	RS 485, 8N1 and 8N2, Modbus RTU, not separated
Baud rate	1200 bit/s ÷ 115200 bit/s
Display	LED, 6 digit, 9mm height, red
Data memory	non-volatile memory, EEPROM type
Protection level	IP 65 optional version with panel cut-out sealing available
Terminals protection	IP 20

Housing type	panel
Housing material	NORYL - GFN2S E1
Housing dimensions	72 x 36 x 97 mm
Mounting hole	66.5 x 32.5 mm
Assembly depth	min. 102 mm
Panel thickness	max. 5 mm
Operating temperature (depending on version)	0°C to +50°C or -20°C to +50°C
Storage temperature (depending on version)	-10°C to +70°C or -20°C to +70°C
Humidity	5 to 90% no condensation
Altitude	up to 2000 meters above sea level
Screws tightening max. torque	0,5 Nm
Max. connection leads diameter	2,5 mm ²
Safety requirements	according to: PN-EN 61010-1 installation category: II pollution degree: 2 voltage in relation to ground: 300V AC insulation resistance: >20MΩ insulation strength between power supply and input/output terminal: 1min. @ 2300V insulation strength between relays terminal: 1min. @ 1350V
EMC	according to: PN-EN 61326-1



This equipment is not intended for use in residential environments and may not provide adequate protection to radio reception in such environments.

4. DEVICE INSTALLATION

The unit has been designed and manufactured in a way assuring a high level of user safety and resistance to interference occurring in a typical industrial environment. In order to take full advantage of these characteristics installation of the unit must be conducted correctly and according to the local regulations.



- Read the basic safety requirements on page 3 prior to starting the installation.
- Ensure that the power supply network voltage corresponds to the nominal voltage stated on the unit's identification label.
- The load must correspond to the requirements listed in the technical data.
- All installation works must be conducted with a disconnected power supply.
- Protecting the power supply clamps against unauthorized persons must be taken into consideration.

4.1. UNPACKING

After removing the unit from the protective packaging, check for transportation damage. Any transportation damage must be immediately reported to the carrier. Also, write down the unit serial number on the housing and report the damage to the manufacturer.

Attached with the unit please find:

- user's manual,
- warranty,
- assembly brackets - 2 pieces.

4.2. ASSEMBLY



- The unit is designed for mounting inside housings (control panel, switchboard) insuring appropriate protection against surges and interference. Metal housings must be connected to ground in a way that complies with the governing regulations.
- Disconnect the power supply prior to starting assembly.
- Check the connections are wired correctly prior to switching the unit on.



In order to install the unit, a 66.5 x 32.5 mm mounting hole (Figure 4.1) must be prepared. The thickness of the material of which the panel is made must not exceed 5mm. When preparing the mounting hole take the grooves for catches located on both sides of the housing into consideration (Figure 4.1). Place the unit in the mounting hole inserting it from the front side of the panel, and then fix it using the brackets (Figure 4.2). The minimum distances between the centre points of multiple units - due to the thermal and mechanical conditions of operation - are 91 mm x 57mm (Figure 4.3).

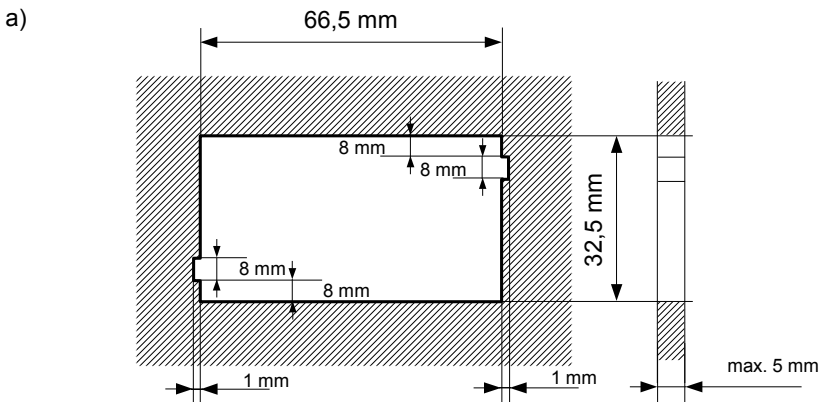

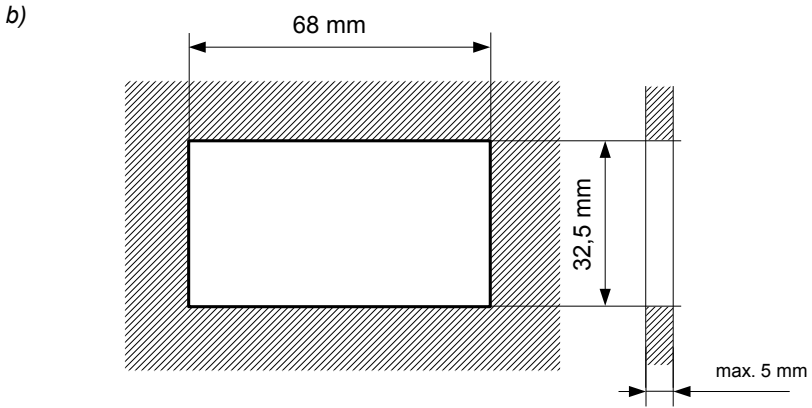

Figure 4.1. Mounting hole dimensions: a) recommended b) allowable

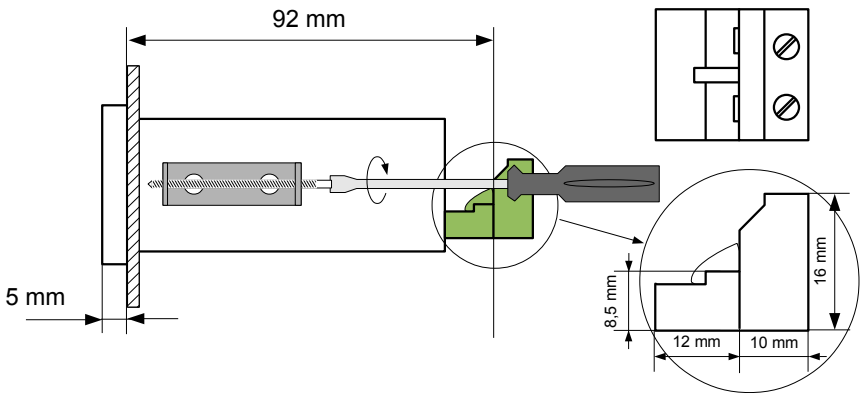

Figure 4.2. Installing of brackets, and dimensions of connectors.

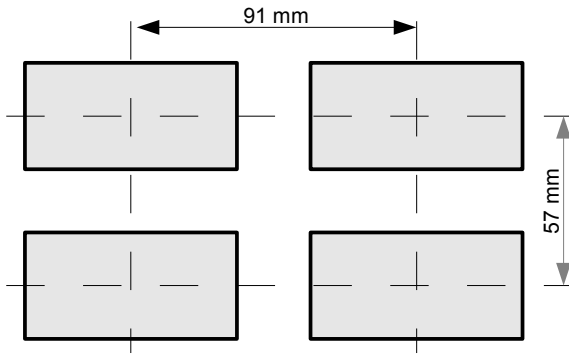

Figure 4.3. Minimum distances when assembly of a number of units

4.3. CONNECTION METHOD

Caution



- Installation should be conducted by qualified personnel . During installation all available safety requirements should be considered. The fitter is responsible for executing the installation according to this manual, local safety and EMC regulations.
- The unit is not equipped with an internal fuse or power supply circuit breaker. Because of this an external time-delay cut-out fuse with minimal possible nominal current value must be used (recommended bipolar, max. 2A) and a power supply circuit-breaker located near the unit. In the case of using a monopolar fuse it must be mounted on the phase cable (L).
- The power supply network cable diameter must be selected in such a way that in the case of a short circuit of the cable from the side of the unit the cable shall be protected against destruction with an electrical installation fuse.
- Wiring must meet appropriate standards and local regulations and laws.
- In order to secure against accidental short circuit the connection cables must be terminated with appropriate insulated cable tips.
- Tighten the clamping screws. The recommended tightening torque is 0.5 Nm. Loose screws can cause fire or defective operation. Over tightening can lead to damaging the connections inside the units and breaking the thread.
- In the case of the unit being fitted with separable clamps they should be inserted into appropriate connectors in the unit, even if they are not used for any connections.
- **Unused clamps (marked as n.c.) must not be used for connecting any connecting cables (e.g. as bridges), because this can cause damage to the equipment or electric shock.**



- If the unit is equipped with housing, covers and sealing packing, protecting against water intrusion, pay special attention to their correct tightening or clamping. In the case of any doubt consider using additional preventive measures (covers, roofing, seals, etc.). Carelessly executed assembly can increase the risk of electric shock.

- After the installation is completed do not touch the unit's connections when it is switched on, because it carries the risk of electrical shock.

Due to possible significant interference in industrial installations appropriate measures assuring correct operation of the unit must be applied. To avoid the unit of improper indications keep recommendations listed below.

- Avoid common (parallel) leading of signal cables and transmission cables together with power supply cables and cables controlling induction loads (e.g. contactors). Such cables should cross at a right angle.
- Contactor coils and induction loads should be equipped with anti-interference protection systems, e.g. RC-type.
- Use of screened signal cables is recommended. Signal cable screens should be connected to the earthing only at one of the ends of the screened cable.
- In the case of magnetically induced interference the use of twisted couples of signal cables (so-called "spirals") is recommended. The spiral (best if shielded) must be used with RS-485 serial transmission connections.
- In the case of interference from the power supply side the use of appropriate anti-interference filters is recommended. Bear in mind that the connection between the filter and the unit should be as short as possible and the metal housing of the filter must be connected to the earthing with largest possible surface. The cables connected to the filter output must not run in parallel with cables with interference (e.g. circuits controlling relays or contactors).

Connections of power supply voltage and measurement signals are executed using the screw connections on the back of the unit's housing (Figure 4.4-4.8).

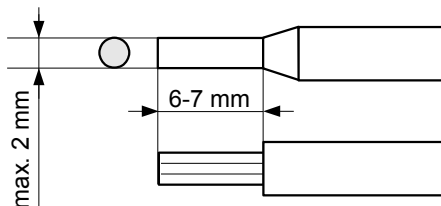

Figure 4.4. Method of cable insulation replacing and cable terminals

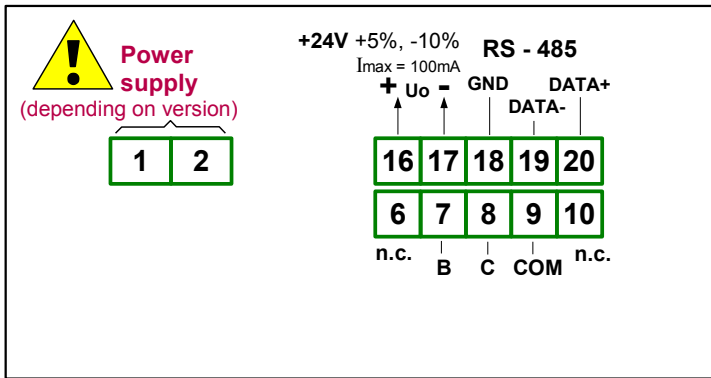

Figure 4.5. Terminals description

Description of control signals' symbols.

- { B } - counting input, pulse;
- { C } - programmable input;
- { COM } - common terminal



All connections must be made while power supply is disconnected !

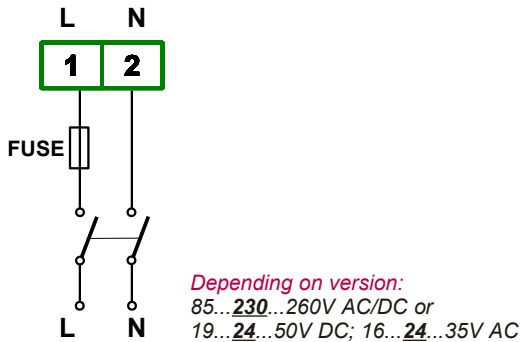

Figure 4.6. Connection of power supply

Warning!
Terminals 9 and 17 has
no internal connection.

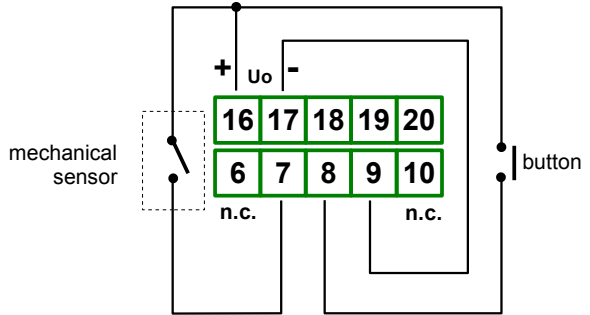

Figure 4.7. Example of connection with mechanical sensor and external button

Warning!
Terminals 9 and 17 has
no internal connection.

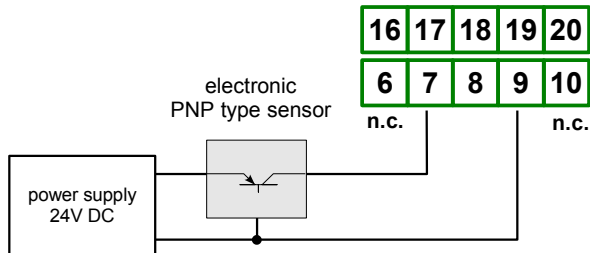

Figure 4.8. Example of connection with electronic sensor

4.4. MAINTENANCE

The unit does not have any internal replaceable or adjustable components available to the user. Pay attention to the ambient temperature in the room where the unit is operating. Excessively high temperatures cause faster ageing of the internal components and shorten the fault-free time of unit operation.

In cases where the unit gets dirty do not clean with solvents. For cleaning use warm water with small amount of detergent or in the case of more significant contamination ethyl or isopropyl alcohol.



Using any other agents can cause permanent damage to the housing.



Product marked with this symbol should not be placed in municipal waste. Please check local regulations for disposal and electronic products.

5. FRONT PANEL DESCRIPTION



Symbols and functions of push-buttons:



Symbol used in the manual: **[ESC/MENU]**

Functions:

- Enter to main menu (press and hold by at least 2 sec.)
- Exit the current level and Enter to previous menu (or measure mode)
- Cancel the changes made in parameter being edited



Symbol used in the manual: **[ENTER]**

Functions:

- Start to edit the parameter
- Enter to the sub-menu,
- Confirmation of changes made in parameter being edited



Symbol used in the manual: **[^] [v]**

Functions:

- Change of the present menu,
- Modification of the parameter value



Symbol used in the manual: **[RESET]**

Functions:

- zeroing the counter (see: „*rESet*” option, page: 17), the reset must be confirmed by **[ENTER]** button.

6. PRINCIPLE OF OPERATION

After turning the power supply on, device ID and software version are showed on the display, next the data **stored while power supply off** are restored and device goes to the selected operation mode.

6.1. MEASUREMENT MODE

In the counting mode (normal mode), the device counts pulses “delivered” to counting input.

Counter recalculates result, and shows it on the display. If the result is out of permissible counter range (from “-99999” to “999999”), special warning is displayed in place of the result. The warning type depends on the result and can be:

- “-Hi-” - if the result is higher than “999999”,

- “-Lo-” -if the result is lower than“-99999”.

Any time the counter can be zeroed at by:

- pressing of the [RESET] push-button and the confirmation of the [ENTER] button,
- activating the external programmable input (see: “rESEt” menu),
- presets of the internal registers via RS-485 interface.

After zeroing, the result equal to the “oFFSEt” parameter is displayed. (see: “PrESCA” menu).

All accessible parameters can be changed by entering the menu (see: **DEVICE PROGRAMMING**). Use the local keyboard or the remote controller to do it. (Note: all parameters can be remote changed via RS-485 interface).



Counting is independent of operation mode of the counter. They are continued (in background) even in menu mode.

6.2. THE DIGITAL FILTER

To enable the connection of the simple switches as detectors, special digital filter has been build into the device. This filter allows the counter to proper counting pulses regardless of the vibration of the contacts of the switches.

The condition of proper counting is providing of time periods of the pulses. The filter can be set to blocking frequencies higher than 10, 20, 30, 40, 50 ,60 ,70, 80 and 90Hz. The time periods of stable states "0" (t_0) and "1" (t_1) of pulses must be not shorter than $1/2F$, where F the filtered frequency in Hz. See the table below (Tab. 6.1) to check proper periods for all frequencies.

filter setting (F)	t_0, t_1	input signal frequency	input type
OFF	166.0 μ s	3 kHz	electronic input
10	50.0 ms	10 Hz	electronic or contact input
20	25.0 ms	20 Hz	
30	16.7 ms	30 Hz	
40	12.5 ms	40 Hz	
50	10.0 ms	50 Hz	
60	8.3 ms	60 Hz	
70	7.2 ms	70 Hz	
80	6,3 ms	80 Hz	
90	5,6 ms	90 Hz	

Tab. 6.1. Time periods t_0, t_1 depend on filtered frequency.

When the filter is turned off, time periods t_0 i t_1 must be longer than $166 \mu\text{s}$ (see Figure 6.1), and maximum counted frequency is equal 3 kHz.

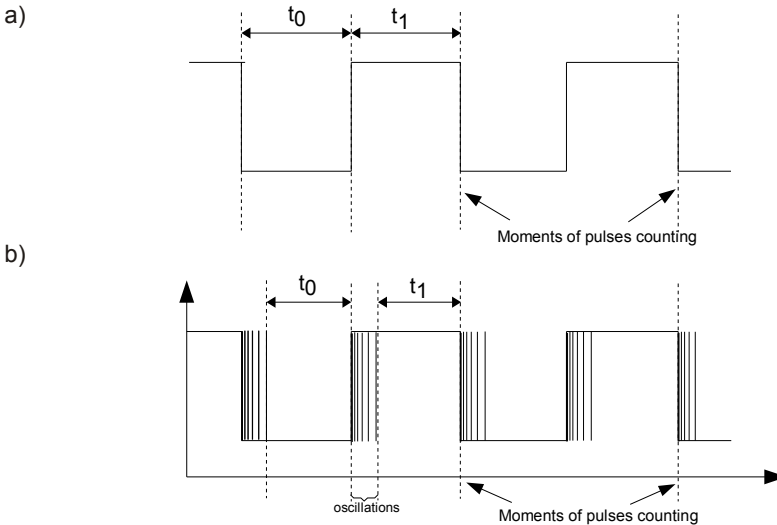

Figure 6.1. The traces of signals:

a) without contacts oscillations, b) with contacts oscillations

7. DEVICE PROGRAMMING

The device menu allow user to set all parameters connected to operation of measurement input, control modes, communication via RS-485 and access settings. The meaning of the particular parameters is described in paragraph **MENU DESCRIPTION**.

7.1. PROGRAMMING MENU

To enter main menu (being in the measurement mode) operator must to press and hold at least 2 sec. **[ESC/MENU]** button. If the user password is defined (see parameter "SEtCod"), operator have to enter correct one before proceeding to menu options. Entering of the passwords is similar to the edition of numeric parameters (see: **PARAMETERS EDITION**), however presently editing digit is showed only on the display, other digits are replaced by "-" sign.

After entering of last digit of the password first menu position will be displayed (if the password is correct) or warning "Error" in other case.



Pay attention when device parameters are being changed. If it is possible, turn off controlled installation (machine).

Functions of the buttons while sub-menu and parameters choice:



Selection of sub-menu or parameter for editing. Name of selected item (sub-menu or parameter) is displayed.



Operation of **[ENTER]** button depend on present menu position:

- if the name of some sub-menu is displayed - enter this sub-menu; name of the first parameter (or next level sub-menu) is displayed,
- if the name of some parameter is displayed - enter the edition of this parameter; present value of the parameter is displayed,



[ESC/MENU] button allow user to exit present menu level and goes to upper level menu (or measurement mode).



After about 1 min. since last use of the buttons, device exits the menu mode and returns to the measurement mode (only if no parameters are in editing mode).

7.2. PARAMETERS EDITION

To start edition of any parameter user should select name of desired one using **[^]** **[v]** buttons and then press **[ENTER]**.

7.2.1. Numeric parameters (digit change mode)

Numerical parameters are displayed as decimal numbers. The mode of its new value entering depends on chosen edit method (see parameter „**Edit**“).

In mode “by digit” („**Edit**“=“**dig**“) pressing one of the keys **[^]** or **[v]** causes change of current position (flashing digit) or the sign (+/-). Short pressing of the **[ENTER]** button causes change of the position (digit).

Press **[ENTER]** at least 2 seconds to accept the changes, after that question “**SEt?**” is displayed, and user must to confirm (or cancel) the changes. To conform changes (and store it in EEPROM) press **[ENTER]** button shortly after “**SEt?**” is displayed. To cancel the changes press **[ESC]** button shortly after “**SEt?**” is displayed. After that device returns to the menu.

7.2.2. Numeric parameters (slide change mode)

In “slide change” mode („**Edit**“=“**Slid**“), buttons **[^]** and **[v]** has different functions.

To increase edited value press (or press and hold) **[^]** button only, the increasing became quickest as long as button **[^]** is pressed. To slow down the increasing, button **[v]** can be used. If **[v]** is pressed shortly (and button **[^]** is still pressed), increasing slow down for a moment only, if **[v]** is pressed and held while button **[^]** is still pressed the increasing slow down and will be kept on lower speed.

To decrease edited value press (or press and hold) **[V]** button only. The decreasing became quickest as long as button **[v]** is pressed. To slow down the decreasing, button **[^]** can be used. If **[^]** is pressed shortly (and button **[v]** is still pressed), decreasing slow down for a moment only, if **[^]** is pressed and held while button **[v]** is still pressed the decreasing slow down and will be kept on lower speed.

Press **[ENTER]** at least 2 seconds to accept the changes, after that question **"Set?"** is displayed, and user must to confirm (or cancel) the changes. To conform changes (and store it in EEPROM) press **[ENTER]** button shortly after **"Set?"** is displayed. To cancel the changes press **[ESC]** button shortly after **"Set?"** is displayed. After that device returns to the menu.

7.2.3. Switch parameters ("LIST" type)

Switch parameters can be described as a sets of values (a lists) out of which only one of the options available on the list can be selected for the given parameter. Options of switching parameter are selected using **[^]**, **[v]** keys.

Short pressing of **[ENTER]** causes in displaying of the acknowledge question (**"Set?"**). If key **[ENTER]** is pressed again, the changes are accepted, stored in EEPROM and the edition process finished. Pressing the key **[ESC]** after **"Set?"** causes in cancelling of made changes and returning to menu.

Functions of buttons when editing numeric and switching parameters:



While editing numeric parameter:

- change of current (flashing) digit
 - slide change of value (acceleration, deceleration, direction change)
- While editing switch parameter - selection of switch parameter.



If numerical parameter is being edited, a short press of **[ENTER]** button change edited position. A long press of **[ENTER]** button (at least 2 sec.) causes of display a **"Set?"** ask, which allow user to make sure if change of the parameter value is correct. If switch parameter is being edited, a short press of **[ENTER]** button causes of display a **"Set?"** ask. When **[ENTER]** button is pressed again (while **"Set?"** is displayed) the new value of the parameter is stored in EEPROM memory.



Pressing this button operator can cancel the changes done up to now (if they were not approved by **[ENTER]** button after the **"Set?"** ask) and come back to menu

7.3. MENU DESCRIPTION

"Cd 0 - - -" Password checking. If password is set different from **„0000"**, than every enter to main menu follows the entering of password. If entered password is correct first menu position else warning **"Error"** will be displayed, and unit returns to measurement mode.



Due to problem with direct displaying of “m” letter, it is exchanged with special sign “ \bar{m} ”. Independently in user manual letter „m” is used to make it more readable (example: “**modE**”).

7.3.1. “rESEt” parameter

This parameter determines the counter zeroing (reset) sources, and can be set to one of the values:

- “ALL”** - this option enables both manual (using [**RESET**] button) and electronic reset.
- “EL”** - this option enables external programmable input. If an active signal is delivered to this input the counter is zeroed (only if “Pr inP” = “rESEt”), and the result stays zero (or equal to offset) as long as the signal on programmable input is active. To made correct zeroing, input signal must be active at least by 1 ms. In this mode manual reset is disabled.
- “mAn”** - manual reset only. This value enables only manual reset, which can be done by pressing the [**RESET**] button on the front panel. This operation must to be approved by [**ENTER**] button. After zeroing counter displays value equals to “oFFSEt” parameter. In this mode electronic reset is disabled.
- “nonE”** - this option disables both manual and electronic reset.



Zeroing of the counter can be done via RS-485 interface (by presets of some registers with value 0000h) independently of the „rESEt” parameter value. After zeroing the counter, displayed value is equal to „oFFSEt” parameter. Remote zeroing is available in all modes (“ALL”, “EL”, “mAn”, „nonE”).

7.3.2. “FiLEr” parameter

This parameter enables the digital filter, which filters the contacts oscillations of switches (mechanical detectors). Digital filter eliminates the counting errors when mechanical detectors are used. This parameter can be set to values: “OFF”, “10” ÷ “90”, where its value express the maximum passed frequency, if “OFF” is set the filter is disabled (see **DIGITAL FILTER**, page 13).

7.3.3. “Pr inP” parameter

This parameter defines the function of the programmable input. When **active state** is delivered to programmable input, it causes of the activating of particular function. This parameter can be set to one of the values:

- “diSAbL”** - programmable input is not active,
- “rESEt”** - zeroing of the counter value (the active state must be longer than 1 ms).
- “inhibi”** - programmable input stops the counting,
- “dirEct”** - active signal on the programmable input changes counting direction

7.3.4. "PrESCA" menu

This menu contains parameter which configure the prescalling parameters (recalculations of counted pulses). This menu allows the user to set individual prescalers, and to scale the counter in desired units. Available options:

- "**mul**" - multiply coefficient , range -99999 do 999999, except 0,
- "**div**" - divide coefficient, range 1 do 999999, (this parameter defines the internal modulo counter),
- "**oFFSEt**" - offset coefficient, range: -99999 do 999999 (constant value added to the result to move the zero point of the current scale),
- "**Point**" - decimal point position.

Displayed result is calculated due to the expression:

$$W = (L_m \times \text{"mul"}) + \frac{L_w \times \text{"mul"}}{\text{"div"}} + \text{"oFFSEt"}$$

- where:
- W - displayed result
 - L_m - the internal main counter value
 - L_w - the internal (modulo) precounter value



Parameter "**div**" can't be set to "000000", entered value is controlled by firmware.

The precounter (modulo) and main counter are internal registers of the counter's firmware and they contain not calculated (by **mul** and **div** parameters) numbers of pulses delivered to the counting inputs {A} and {B}. The modulo counter contains the fractional part of the result (ratio of „**div**” parameter). Main counter contains the integer part of the result (not recalculated). If parameter "**div**" is set to 1, then main counter contains the number of all pulses delivered to counting inputs.

Firmware uses fixed point arithmetic (rounding down).

7.3.5. "rS-485" menu

This menu is connected with RS-485 interface, and sets his properties:

- "**Addr**" - this parameter defines the address of the device, accordingly to Modbus protocol. It can be set in range from 0 to 199. If the value 0 is set then device, responds to frames with address 255 (FFh).
- "**bAud**" - this parameter determines RS-485 interface baud rate. It can be set to one of 8 possible values: "**1.2**", "**2.4**", "**4.8**", "**9.6**", "**19.2**", "**38.4**", "**57.6**", "**115.2**", which respond to the baud rates of 1200, 2400, 4800, 9600, 19200, 38400, 57600 and 115200 bit/s respectively.

- "mbAccE"** - this parameter sets the access to the configuration registers of the device.
Possible values:
- "on"** - configuration registers can be set via RS-485 interface,
 - "oFF"** - configuration registers can not be set via RS-485 interface.



The access to registers no 04h ÷ 07h cant be denied by **"mbAccE"** parameter (see: **LIST OF REGISTERS**).

"mbtime" - this parameter defines maximal time (sec) between following frames received by the device. Parameter **"mbtime"** can be set to values from 0 to 99 seconds. The value 0 means that the time will be not controlled.

"rESP" - this parameter defines minimal (additional) delay between the Modbus message and the answer of the device (received and sent via RS-485 interface). This additional delay allows the device to work with poor RS-converters which do not works properly on baud rates higher than 19200. This parameter can be set to one of values:

"Std" - answer as quick as possible, no additional delay

" 10c"

" 20c"

" 50c"

"100c"

"200c"

- answer delayed of 10, 20, 50, 100 of 200 chars respectively, where one character time depends on selected baud rate



In the most cases parameter **"rESP"** should be set to **"Std"** (no additional delay). Unfortunately for some third party RS-converters **"rESP"** should be adjusted experimentally. Table 7.1 contains most frequently used values.

"bAud" parameter	"38.4"	"57.6"	"115.2"
"rESP" parameter	" 10c"	" 20c"	" 50c"

Tab.7.1. Settings of **"rESP"** parameter

7.3.6. "SEtcod" parameter

User password (4-digits number). If this parameter is set at value "0000", user password is turned off.

If the user do not remember his password, the access to the menu is possible by the "one-use password". To get this password please contact with Marketing Division. "Single use password" can be used only one time, after that it is destroyed. Entering this password causes in clearing of user password, it means sets the user password to „0000“.



The "one-use password" can be used **ONE TIME ONLY**, it is impossible to use it again! The "one-use password" can be restored by Service Division only.

7.3.7. "briGHt" parameter

This parameter allows user to set bright of the LED display, bright can be set to conventional values from 1 to 8.

7.3.8. "Edit" parameter

This parameter allows to change the edition mode of numerical parameters:

- "dig"** - the change to "by digit" mode,
- "Slid"** - slide change mode.

7.3.9. "dEFS" parameter

This setting allows to restore the factory settings of the device. To get the access to this option special password is required: „5465“, next the device displays acknowledge question „SEt?“. Press **[ENTER]** to acknowledge the restoring of factory settings or **[ESC]** to cancel.

7.4. MENU STRUCTURE

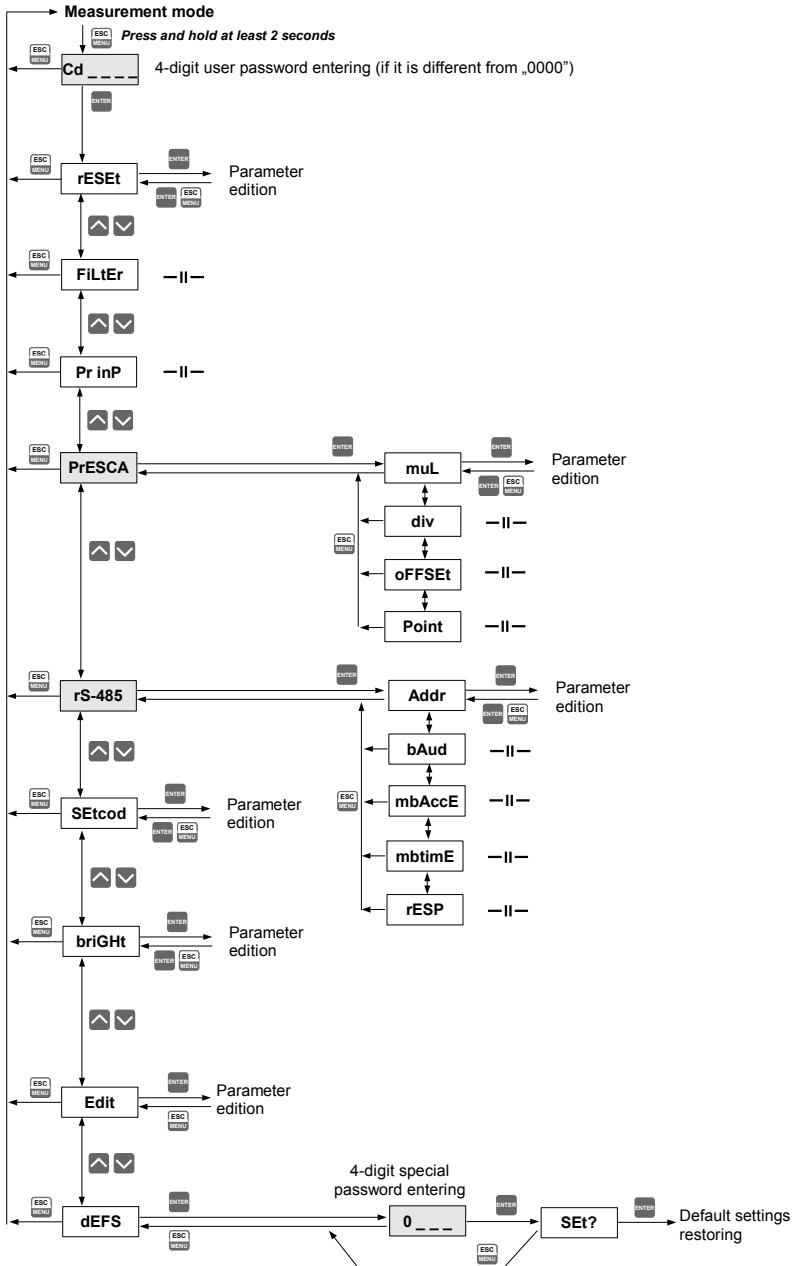

8. EXAMPLES OF PRESCALER PARAMETERS CALCULATION

Problem: to show the number of revolutions with desired precision

Essential data:

- number of pulses per revolution given by sensor
- measurement precision.

Example 1

Data:

- 100 pulses/revolution
- precision – up to 1 revolution

Settings :

muL = “1”
div = “100”
point = “0.”

Example 2

Data:

- 250 pulses/revolution
- precision – up to 0.1 of revolution

Settings:

muL = “1”
div = “25”
point = “0.0”

9. THE MODBUS PROTOCOL HANDLING

Transmission parameters: 1 start bit, 8 data bits, 1 or 2 stop bit (2 bits are send, 1 and 2 bits are accepted when receive), no parity control

Baud rate: selectable from: 1200 to 115200 bits/second

Transmission protocol: MODBUS RTU compatible

The device parameters and display value are available via RS-485 interface, as HOLDING-type registers (numeric values are given in U2 code) of Modbus RTU protocol. The registers (or groups of the registers) can be read by 03h function, and wrote by 06h (single registers) or 10h (group of the registers) accordingly to Modbus RTU specification. Maximum group size for 03h and 10h functions can not exceeds 16 registers (for single frame).



The device interprets the broadcast messages, but then do not sends the answers.

9.1. LIST OF REGISTERS

Register	Write	Range	Register description
01h ¹	No	see descr.	Display value - higher word.
02h ¹	No	see descr.	Display value - lower word.
03h	No	see descr.	The status of the displayed value: 0000h - data valid, 0080h - overflow, warning “-Hi-” is displayed 0040h - underflow, warning “-Lo-” is displayed
04h ²	Yes	see descr.	State of precounter - this is internal modulo N counter, where N = “ div ”, overflow of this counter causes incrementation/decrementation of main counter.
05h ²	Yes	see descr.	State of precounter (low word)
06h ²	Yes	see descr.	Main counter value - high word
07h ²	Yes	see descr.	Main counter value - low word.
11h	Yes	0 ÷ 3	“ Pr inP ” option (programmable input operation mode): 0 - mode “ diSAbl ”, disabled 1 - mode “ inhibi ”, zeroing the counter, 2 - mode “ inhibi ”, holding of the counter, 3 - mode “ dirEct ”, counter direction
12h	Yes	0 ÷ 3	“ rESet ” option (main counter clearing mode): 0 - mode “ ALL ”, 1 - mode “ EL ”, reset with programmable input and RS-485 interface 2 - mode “ mAn ”, reset with [RESET] button and RS-485 interface 3 - mode “ none ”, reset with RS-485 interface only
14h	Yes	0 ÷ 9	“ FILtEr ” option (filtering rate): 0 - for input signal up to 3kHz frequency; 1 - up to 10Hz; 2 - up to 20Hz; 3 - up to 30Hz; 4 - up to 40Hz; 5 - up to 50Hz; 6 - up to 60Hz; 7 - up to 70Hz; 8 - up to 80Hz; 9 - up to 90Hz;
16h	Yes	see descr.	“ mul ” in “ PrESCA ” menu (main counter multiplier, high word); counter always shows main counter value recalculated by prescaler coefficients
17h	Yes	see descr.	“ mul ” in “ PrESCA ” menu (main counter multiplier, low word); Cumulative value of registers 16h and 17h: from -99999 to 999999
18h	Yes	see descr.	“ div ” parameter in “ PrESCA ” menu (input divider, high word); content of main counter is incremented by 1 every n pulses on input B, where n is content of precounter registers
19h	Yes	see descr.	“ div ” parameter in “ PrESCA ” menu (input divider, low word); Cumulative value of registers 18h and 19h: from 1 to 999999
1Ah ⁶	Yes	see descr.	“ oFFSEt ” parameter in “ PrESCA ” menu (high word)
1Bh ⁶	Yes	see descr.	“ oFFSEt ” parameter in “ PrESCA ” menu (low word) Cumulative value of registers 1Ah and 1Bh: from -99999 to 999999
1Ch	Yes	0+5	“ Point ” parameter in “ Presca ” menu (decimal point position) 0 - “ 0 ”; 1 - “ 0.0 ”; 2 - “ 0.00 ”; 3 - “ 0.000 ”; 4 - “ 0.0000 ”; 5 - “ 0.00000 ”
20h ³	Yes	0 ÷ 199	Device address

Register	Write	Range	Register description
21h	No	20CCh	Device identification code (ID)
22h ⁴	Yes	0 ÷ 7	“bAud” parameter in “rS-485” menu (baud rate); 0 - 1200 baud; 1 - 2400 baud; 2 - 4800 baud; 3 - 9600 baud; 4 - 19200 baud; 5 - 38400 baud; 6 - 57600 baud; 7 - 115200 baud
23h ⁵	Yes	0 ÷ 1	“mbAccE” parameter in “rS-485” menu (permission to write registers via RS-485 interface); 0 - write denied ; 1 - write allowed
24h	Yes	see descr.	Parameters of “SECU” menu (binary format (0 - „oFF”, 1 - „on”): bit 0 - “A rEL” parameter; bit 4 - “A oFFS” parameter
25h	Yes	0 ÷ 5	“rESP” parameter in “rS-485” menu (additional response delay); 0 - no additional delay; 1 - “10c” option; 2 - “20c” option; 3 - “50c” option; 4 - “100c” option; 5 - “200c” option;
27h	Yes	0 ÷ 99	“mbtImE” parameter in “rS-485” menu (maximum delay between received frames); 0 - no delay checking; 1 ÷ 99 - maximum delay expressed in seconds
2Dh	Yes	1 ÷ 8	“briGHt” parameter (display brightness); 1 - the lowest brightness; 8 - the highest brightness
2Fh	Yes	0 ÷ 1	“Edit” parameter (numerical parameters edit mode); 0 - “dig” mode; 1 - “SLid” mode

- 1 - if overflow or underflow occurs (**“-Hi-”** or **“-Lo-”**), read of registers 01h and 02h (single registers) it returns recalculated number of pulses (while the overload of display quantity is very big this value can be erroneous). Register 03h returns according error code.
- 2 - Pre-set of 0000h to these registers (04h, 05h, 06h and 07h,) causes by zeroing of main counter and precounter content.
- 3 - after writing to register no 20h the device responds with an “old” address in the message.
- 4 - after writing to register no 22h the device responds with the new baud rate.
- 5 - the value of the **“mbAccE”** parameter is also connected to write to this register, so it is possible to block a writes, but impossible to unblock writes via RS-485 interface. The unblocking of the writes is possible from menu level only.
- 6 - numbers written to holding registers of relays thresholds are interrelated with each other auto-correction. For example. Pre-set to reg. 1Bh (threshold lower word) of value, which together with content of register 1Ah (threshold higher word) gets value from behind of allowable range, will fails. Over more preset to reg 1Ah of value which together with content of register 1Bh gets value from behind of allowable range, will modify the content of register 1Bh, in that way to it’s value together with register 1Ah be located in allowable range. If appropriate modification is impossible, write fails. It is recommended to write threshold values in presented manner: first pre-set of threshold higher word, and next threshold lower word. Similarly storing of thresholds registers of another relays is being realised with each other correction.

9.2. TRANSMISSION ERRORS DESCRIPTION

If an error occurs while write or read of single register, then the device sends an error code according to Modbus RTU specifications.

Error codes:

- 01h** - illegal function (only functions 03h, 06h and 10h are available),
- 02h** - illegal register address
- 03h** - illegal data value
- 08h** - no write permission (see: **“mbAccE”** parameter)

9.3. EXAMPLES OF QUERY/ANSWER FRAMES

Examples apply for device with address 1. All values are represent hexadecimal.

Field description:

ADDR	Device address on Modbus network
FUNC	Function code
REG H,L	Starting address (address of first register to read/write, Hi and Lo byte)
COUNT H,L	No. of registers to read/write (Hi and Lo byte)
BYTE C	Data byte count in answer frame
DATA H,L	Data byte (Hi and Lo byte)
CRC L,H	CRC error check (Hi and Lo byte)

1. Read of device ID code

ADDR	FUNC	REG H,L		COUNT H,L		CRC L,H	
01	03	00	21	00	01	D4	00

The answer:

ADDR	FUNC	BYTE C	DATA H,L		CRC L,H	
01	03	02	20	CC	A1	D1

DATA - identification code (20CCh)

2. Change of the device address from 1 to 2 (write to reg. 20h)

ADDR	FUNC	REG H,L		DATA H,L		CRC L,H	
01	06	00	20	00	02	09	C1

DATA H - 0

DATA L - new device address (2)

The answer (the same as the message):

ADDR	FUNC	REG H,L		DATA H,L		CRC L,H	
01	06	00	20	00	02	09	C1

3. Change of baud rate of all devices connected to the net (BROADCAST message).

ADDR	FUNC	REG H,L		COUNT H,L		CRC L,H	
00	06	00	22	00	04	29	D2

DATA H - 0

DATA L - 4, new baud rate 19200 baud



Device do not reply to BROADCAST-type messages.

4. Read of the displayed value (higher word):

ADDR	FUNC	REG H,L		COUNT H,L		CRC L,H	
01	03	00	01	00	01	D5	CA

Response, while normal operation (no errors):

ADDR	FUNC	BYTE C	DATA H,L		CRC L,H	
01	03	02	00	00	B8	4C

DATA H, L - 0000h = 0, higher word of displayed value = 00

5. Read of the displayed value (high and low word),

ADDR	FUNC	REG H,L		COUNT H,L		CRC L,H	
01	03	00	01	00	02	95	CB

Response, while normal operation (no errors):

ADDR	FUNC	BYTE C	DATA H1,L1		DATA H2,L2		CRC L,H	
01	03	04	00	00	00	57	BB	CD

DATA - 00000057h = 87, displayed value = 87

6. Settings of the programmable inputs parameters, "Pr InP"="rESET"

ADDR	FUNC	REG H,L		DATA H,L		CRC L,H	
01	06	00	11	00	01	18	0F

The answer (the same as the message):

ADDR	FUNC	REG H,L		DATA H,L		CRC L,H	
01	06	00	11	00	01	18	0F

7. Try to write illegal data value into baud rate register

ADDR	FUNC	REG H,L		DATA H,L		CRC L,H	
01	06	00	22	00	09	E9	C6

DATA L = 9 - value exceeds allowable range (0÷7)

The answer (exception code 03h - illegal data value):

ADDR	FUNC	ERR	CRC L,H	
01	86	03	02	61



There is no full implementation of the Modbus Protocol in the device. The functions presented above are available only.

10. DEFAULT AND USER'S SETTINGS LIST

<i>Parameter</i>	<i>Description</i>	<i>Default value</i>	<i>User's value</i>	<i>Desc. page</i>
Settings of programmable input, zeroing, filtering, and counting mode				
rESEt	Clearing (zeroing) source of main counter	ALL		17
FILtEr	Digital filtration rate	0		17
Pr inP	Programmable input function	diSAbL		17
Prescaler settings (menu "PrESCA")				
muL	multiplier	1		18
div	divider	1		18
oFFSEt	Offset - constant value added to the result to move the zero point of the current scale	0		18
Point	Decimal point position	0.0		18
RS 485 interface configuration ("rS-485" menu)				
Addr	Device address	1		18
bAud	Baud rate	9600		18
mbAccE	Permission to changes of configuration registers	on		19
mbtimE	Maximum delay between received messages	0		19
rESP	Additional delay of answer transmission	Std		19
Display parameters				
briGHt	Display brightness	bri6		20
Configuration of numerical parameters edition				
Edit	Numerical parameters edit mode	dig		20

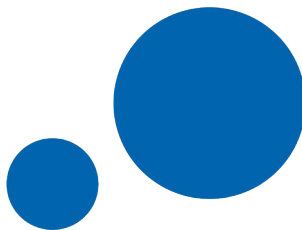

**SIMEX Sp. z o.o.
ul. Wielopole 11
80-556 Gdańsk
Poland**

**tel.: (+48 58) 762-07-77
fax: (+48 58) 762-07-70**

**<http://www.simex.pl>
e-mail: info@simex.pl**