

# DMP 334i

## Precision-Pressure Transmitter for High Pressure

Thinfilm Sensor

accuracy according to EN IEC 62828-2:  
0.1 % span



### Nominal pressure

from 0 ... 600 bar up to 0 ... 2200 bar

### Analogue output

2-wire: 4 ... 20 mA  
others on request

### Special characteristics

- ▶ welded pressure sensor
- ▶ turn-down 10:1
- ▶ excellent accuracy
- ▶ robust and long-term stable

### Optional versions

- ▶ communication interface for adjusting offset, span and damping
- ▶ pressure port  
M20 x 1.5 or 9/16 UNF
- ▶ different kinds of electrical connections

The precision pressure transmitter DMP 334i is a consistent further development of the approved industrial pressure transmitter DMP 334. Basic element is a thinfilm sensor which is welded with the pressure port.

The integrated digital electronics compensates actively sensor specific deviations like non-linearity and thermal error.

It is therefore possible to offer a high pressure transmitter with excellent metrological qualities.

### Preferred areas of use are



Plant and machine engineering  
Test benches



Commercial vehicles and  
mobile hydraulics



# DMP 334i

Precision Pressure Transmitter

Technical Data

Input pressure range						
Nominal pressure gauge	[bar]	600 <sup>1</sup>	1000	1600	2000	2200
Overpressure	[bar]	800	1400	2200	2800	2800

<sup>1</sup> only available with pressure port G1/2" EN 837

Output signal / Supply	
Standard	2-wire: 4 ... 20 mA / $V_s = 12 \dots 36 V_{DC}$
Options	2-wire: 4 ... 20 mA with communication interface <sup>2</sup>

<sup>2</sup> only possible with el. connection Binder series 723 (7-pin)

Performance	
Accuracy	IEC 60770 <sup>3</sup> : $\leq \pm 0.1 \%$ span
performance after turn-down	no change of accuracy for calculation use the following formula: $\leq \pm (0.1 + 0.015 \times \text{turn down}) \%$ span with turn-down = nominal pressure range / adjusted range e.g. with a turn-down of 10:1 following accuracy is calculated: $\leq \pm (0.1 + 0.015 \times 10) \%$ span i.e. accuracy is $\leq \pm 0.25 \%$ span
Permissible load	current 2-wire: $R_{max} = [(V_s - V_{s \text{ min}}) / 0.02 A] \Omega$
Influence effects	supply: 0.05 % span / 10 V      load: 0.05 % span / k $\Omega$
Long term stability	$\leq \pm (0.1 \times \text{turn-down}) \%$ span / year at reference conditions
Response time	approx. 10 msec
Adjustability (option) <sup>4</sup>	configuration of following parameters possible (interface / software necessary): - electronic damping: 0 ... 100 sec - offset: 0 ... 90 % span - turn down of span: max. 10:1

<sup>3</sup> accuracy according to EN IEC 62828-2– limit point adjustment (non-linearity, hysteresis, repeatability)

<sup>4</sup> adjustable version is only possible in combination with Binder Series 723, 7-pin;

software, interface, and cable have to be ordered separately (software appropriate for Windows® 95, 98, 2000, NT Version 4.0 or higher, and XP)

Thermal effects (Offset and Span) / Permissible temperatures	
TC, average	$< 0.25 \%$ span / 10 K      in compensated range - 20 ... 85 °C
Permissible temperatures	medium: - 40 ... 140 °C      electronics / environment: - 25 ... 85 °C      storage: -40 ... 100 °C

Electrical protection	
Short-circuit protection	permanent
Reverse polarity protection	no damage, but also no function
Electromagnetic compatibility	emission and immunity according to EN 61326

Mechanical stability	
Vibration	10 g RMS (20 ... 2000 Hz)      according to DIN EN 60068-2-6
Shock	100 g / 11 msec.      according to DIN EN 60068-2-27

Materials	
Pressure port	stainless steel 1.4542 (17-4 PH)
Housing	stainless steel 1.4404 (316L)
Option field housing	stainless steel 1.4301 (304); cable gland M16x1.5, brass, nickel plated (clamping range 2 ... 8 mm)
Seals	none (welded)
Diaphragm	stainless steel 1.4542 (17-4 PH)
Media wetted parts	pressure port, diaphragm

Miscellaneous	
Current consumption	signal output current:      max. 25 mA
Weight	approx. 300 g
Installation position	any
Operational life	$p_N = 600 \text{ bar}$ : 100 million load cycles $p_N > 600 \text{ bar}$ : 10 million load cycles
CE-conformity	EMC Directive: 2014/30/EU      Pressure Equipment Directive: 2014/68/EU (module A)

### Wiring diagrams

2-wire-system (current)

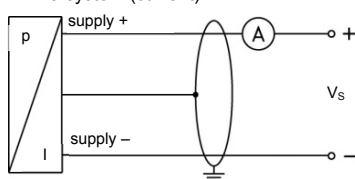

© BD SENSORS s.r.o. – The specifications given in this document represent the state of engineering at the time of publishing. We reserve the right to make modifications to the specifications and materials.

Pin configuration						
Electrical connections	ISO 4400 	Binder 723 (5-pin) 	Binder 723/423 (7-pin) 	M12x1/ metal (4-pin) 	field housing  Vs+ Vs- GND	cable colours (IEC 60757)
Supply + Supply -	1 2	3 4	3 1	1 2	Vs + Vs -	WH (white) BN (brown)
Shield	ground pin $\oplus$	5	2	4	GND $\oplus$	GNYE (green-yellow)
Communication interface <sup>5</sup>	RxD TxD GND	- - -	4 5 7	- - -	- - -	- - -

<sup>5</sup> may not be connected directly with the PC (the suitable adapter is available as accessory)

### Electrical connections (dimensions in mm)

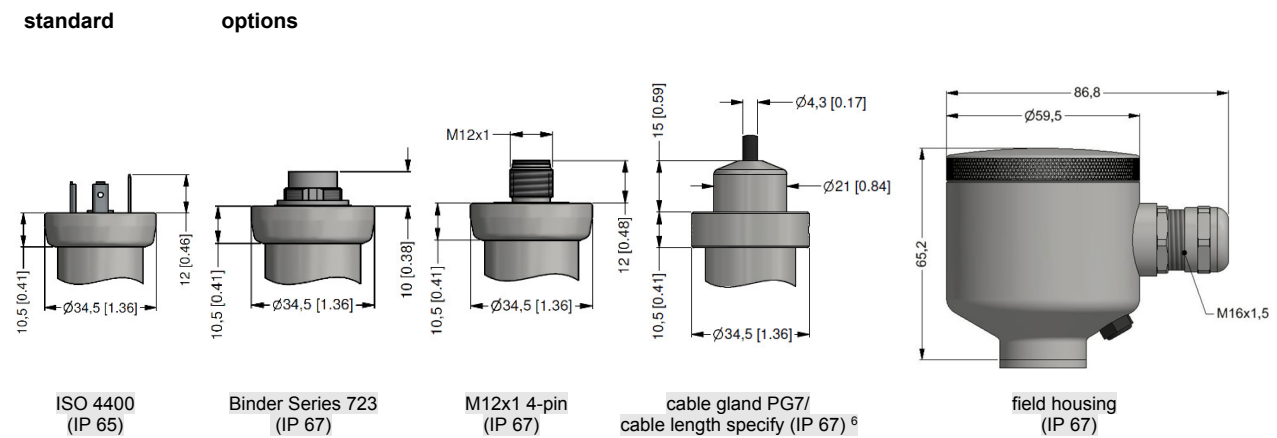

⇒ universal field housing in stainless steel 1.4404 (316 L) with cable gland M20x1.5 (ordering code 880) and other versions on request

<sup>6</sup> standard: 2 m PVC cable (without ventilation tube, permissible temperature: -5 ... 70 °C)

### Mechanical connection (dimensions in mm)

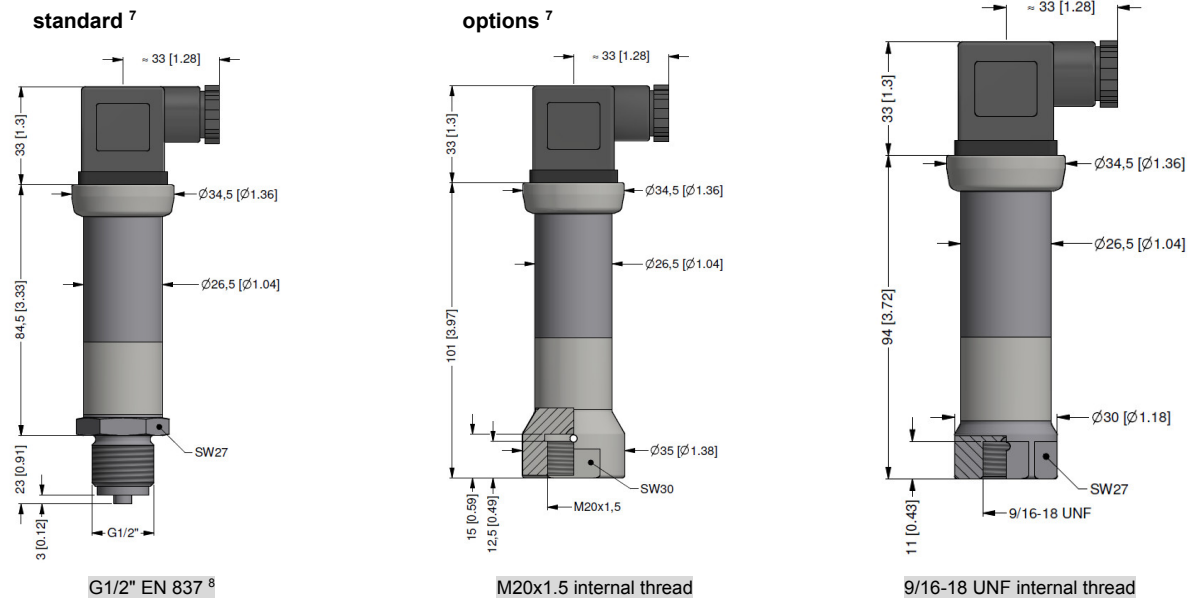

<sup>7</sup> adjustable version is only possible in combination with Binder Series 723, 7 pin

<sup>8</sup> According to EN 837, the pressure port and the complement at pressure over 1000 bar must be preferably made of stainless steel with a tensile strength of  $R_P > 260 \text{ N/mm}^2$  in accordance with DIN 17440. The maximum allowed pressure is 1600 bar!

The manufacturer provides the EU declaration of conformity.

Calibration - All production undergoes output control, which is performed by comparison with standards. The traceability of standards and working gauges is ensured in accordance with Act No. 505/1990, as amended, on metrology.

The manufacturer offers the possibility to supply sensors calibrated in the calibration laboratory of BD SENSORS, accredited according to ČSN EN ISO / IEC 17025: 2018.

## Ordering code DMP 334i

9.3.2021

DMP 334i

□	□	□	-	□	□	□	-	□	□	-	□	□	-	□	□	-	□	□
---	---	---	---	---	---	---	---	---	---	---	---	---	---	---	---	---	---	---

<b>Pressure</b>																				
Gauge	1	4	0																	
<b>Input [bar]</b>																				
0 ... 600 <sup>1</sup>				6	0	0	3													
0 ... 1000				1	0	0	4													
0 ... 1600				1	6	0	4													
0 ... 2000				2	0	0	4													
0 ... 2200				2	2	0	4													
Customer				9	9	9	9													
<b>Output</b>																				
4 ... 20 mA / 2-wire																	1			
Customer																	9			
<b>Accuracy</b>																				
0,1 %																	1			
Customer																	9			
<b>Electrical connection</b>																				
Connector DIN 43650 (ISO 4400) (IP 65)																	1	0	0	
Connector Binder 723 5-pin (IP 67)																	2	0	0	
Cable gland PG7 / cable length specify (IP 67)																	4	0	0	
+ PVC cable / 1 m																				
Connector DIN 43650 (ISO 4400) - potting compound inside (IP 67)																	E	0	0	
Connector M12 x 1, 4-pin (IP 67)																	M	0	0	
Connector M12 x 1, 4-pin (IP 67) - metal																	M	1	0	
Customer																	9	9	9	
<b>Mechanical connection</b>																				
G 1/2" EN 837 (P <sub>N</sub> ≤ 1000 bar) <sup>2</sup>																	2	0	0	
M 20 x 1,5 internal thread																	D	2	8	
9/16 UNF internal thread																	V	0	0	
Customer																	9	9	9	
<b>Seals</b>																				
Without seals - welded																		2		
Customer																		9		
<b>Special version</b>																				
Standard																		1	1	1
RS-232 interface <sup>3</sup>																		1	2	1
Customer																		9	9	9

0,...without additional charge  
 On request ... in accordance with the producer

Surcharges for calibration are not subject to any discounts. Subject to change. □  
 This document contains the specification for ordering the product;  
 detailed technical parameters of the product and its possible variants are given in the data sheet.  
 BD SENSORS reserves the right to change sensor specifications without further notice.

1 only available with pressure port G1/2" EN 837  
 2 According to EN 837, the pressure port and the complement, at pressure over 1000 bar must be preferably made of stainless steel with a tensile strength of RP > 260 N/mm<sup>2</sup> in accordance with DIN 17440. The maximum allowed pressure is 1600 bar!  
 3 RS-232 interface only possible with el. connection Binder serie 723/423 (7pin)  
 Software, Interface and cable for DMP 334i with option RS-232 have to be order separately  
 (Ordering code: CIS Set 510; Software appropriate for Windows® 95, 98, 2000, NT Version 4.0 or newer and XP)

