

DMP 334

Industrial Pressure Transmitter for High Pressure

Thinfilm Sensor

accuracy according to EN IEC 62828-2:
0.35 % span



Nominal pressure

from 0 ... 600 bar up to 0 ... 2200 bar

Analogue output

2-wire: 4 ... 20 mA
3-wire: 0 ... 10 V
others on request

Special characteristics

- ▶ extremely robust and excellent long-term stability
- ▶ pressure sensor welded

Optional versions

- ▶ IS-version
Ex ia = intrinsically safe for gases and dusts
- ▶ pressure port: M20 x 1.5 or 9/16 UNF
- ▶ adjustability of span and offset
- ▶ different kinds of electrical connections

The industrial pressure transmitter DMP 334 has been especially designed for use in hydraulic systems up to 2200 bar. The base element of DMP 334 is a thinfilm sensor, that is welded with the pressure port and meets high demands of accuracy and reliability.

All of characteristics and the excellent measurement data of DMP 334 as well as distinguished offset stability offer a pressure transmitter with easy handling, reliability and robustness for hydraulic user. The DMP 334 is deliverable with standard HP connections.

Preferred areas of use are



Plant and Machine Engineering



Commercial Vehicles and Mobile Hydraulics



Input pressure range						
Nominal pressure gauge	[bar]	600 ¹	1000	1600	2000	2200
Overpressure	[bar]	800	1400	2200	2800	2800
Burst pressure ≥	[bar]	3000	4000	6000	6000	6000
¹ only available with pressure port G1/2" EN 837						
Output signal / Supply						
Standard	2-wire:	4 ... 20 mA / V _S = 12 ... 36 V _{DC}				
Option IS-protection	2-wire:	4 ... 20 mA / V _S = 14 ... 28 V _{DC}				
Option 3-wire	3-wire:	0 ... 10 V / V _S = 14 ... 30 V _{DC}				
Performance						
Accuracy	≤ ± 0.35 % span IEC 60770 ²					
Permissible load	current 2-wire: R _{max} = [(V _S - V _S min) / 0.02 A] Ω voltage 3-wire: R _{min} = 10 kΩ					
Influence effects	supply: 0.05 % span / 10 V			load: 0.05 % span / kΩ		
Long term stability	≤ ± 0.2 % span / year					
Response time	< 5 msec					
Adjustability ³	Adjustment of offset is possible within the range of ± 5 % of the nominal pressure range, please select "041" as a special version in the ordering code.					
² accuracy according to EN IEC 62828-2 – limit point adjustment (non-linearity, hysteresis, repeatability) ³ adjustable version is not possible in combination with IS-version, compact field housing and cable outlet						
Thermal effects (Offset and Span) / Permissible temperatures						
Thermal error	≤ ± 0.25 % span / 10 K in compensated range -20 ... 85 °C					
Permissible temperatures	medium: -40 ... 140 °C		electronics / environment: -40 ... 85 °C		storage: -40 ... 100 °C	
Electrical protection						
Short-circuit protection	permanent					
Reverse polarity protection	no damage, but also no function					
Electromagnetic compatibility	emission and immunity according to EN 61326					
Mechanical stability						
Vibration	10 g RMS (20 ... 2000 Hz)					
Shock	100 g / 11 msec.					
Materials						
Pressure port	stainless steel 1.4542 (17-4 PH)					
Housing	standard: stainless steel 1.4404 (316L) field housing: stainless steel 1.4404 (316L), cable gland: brass, nickel plated					
Option field housing	stainless steel 1.4301 (304); cable gland M16x1.5, brass, nickel plated (clamping range 2 ... 8 mm)					
Seals (media wetted)	none (welded version)					
Diaphragm	stainless steel 1.4542 (17-4 PH)					
Media wetted parts	pressure port / diaphragm					
Explosion protection (only for 4 ... 20 mA / 2-wire)						
Approval DX9-DMP 334	IBExU10ATEX1122 X zone 0: II 1G Ex ia IIC T4 Ga zone 20: II 1D Ex ia IIIC T135 °C Da					
Safety technical maximum values	U _i = 28 V _{DC} , I _i = 93 mA, P _i = 660 mW, C _i ≈ 0 nF, L _i ≈ 0 μH, the supply connections have an inner capacity of max. 27 nF to the housing					
Permissible temperatures for environment	in zone 0: -20 ... 60 °C with p _{atm} 0.8 bar up to 1.1 bar in zone 1 or higher: -40/-20 ... 70 °C (lower temperature limit depends on the type of cable used)					
Connecting cables (by factory)	cable capacitance: signal line/shield also signal line/signal line: 160 pF/m cable inductance: signal line/shield also signal line/signal line: 1 μH/m					
Miscellaneous						
Current consumption	signal output current:		max. 25 mA			
	signal output voltage:		max. 8,5 mA			
Weight	approx. 240 g					
Installation position	any					
CE-conformity	EMC Directive: 2014/30/EU			Pressure Equipment Directive: 2014/68/EU (module A)		
ATEX Directive	2014/34/EU					
Wiring diagrams						
2-wire-system (current)			3-wire-system (current / voltage)			

DMP 334

Industrial Pressure Transmitter

Technical Data

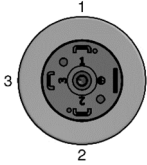
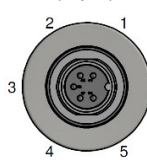
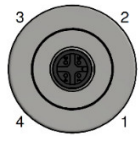
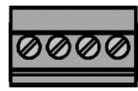
Pin configuration					
Electrical connection	 <p>ISO 4400</p>	 <p>Binder 723 (5-pin)</p>	 <p>M12x1 (4-pin)</p>	 <p>Field housing</p> <p>U_B+ U_B- S+ GND</p>	Cable colours (IEC 60757)
Supply +	1	3	1	IN +	wh (white)
Supply -	2	4	2	IN -	bn (brown)
Signal + (only for 3-wire)	3	1	3	OUT+	gn (green)
Shield	ground pin \oplus	5	4	\oplus	gn/ye (green / yellow)

Electrical connections (dimensions in mm) -drawings of IS-version / cable outlet with stainless steel grip ring -

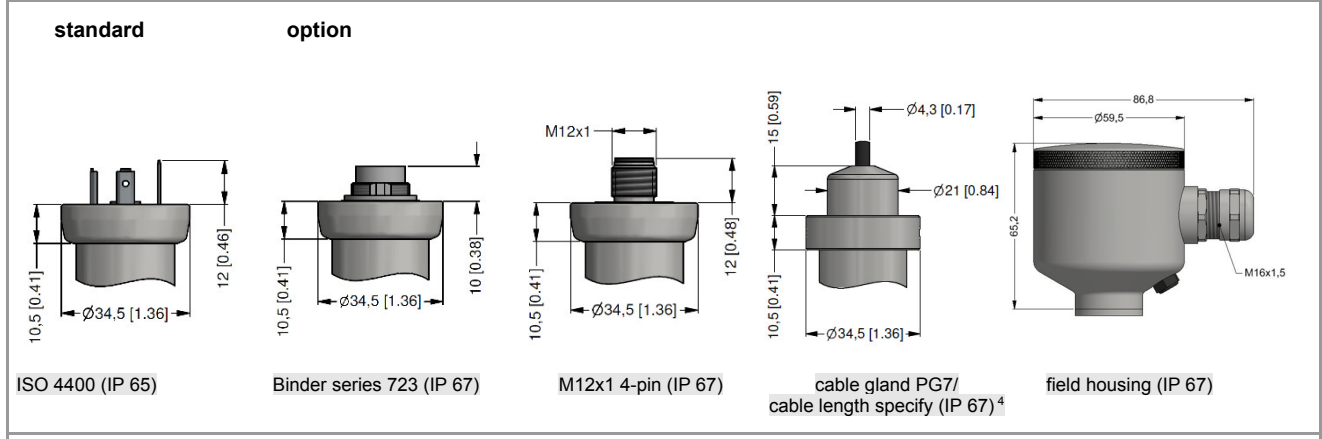

⁴ standard: 2 m PVC cable without ventilation tube (permissible temperature: -5 ... 70 °C)

Mechanical connection (dimensions in mm) -drawings of standard version (adjustable), with plastic grip ring-

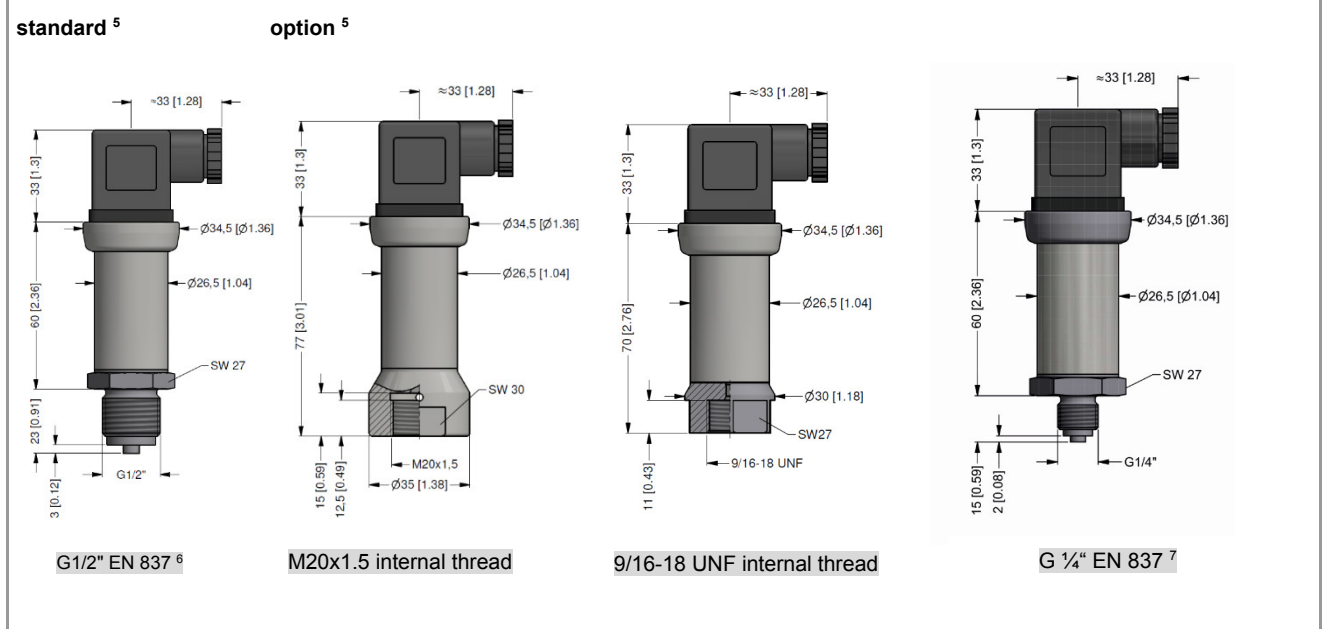

⁵ adjustable version is not possible in combination with IS-version, field housing and cable outlet
⁶ According to EN 837, the pressure port and the complement at pressure over 1000 bar must be preferably made of stainless steel with a tensile strength of R_p > 260 N/mm² in accordance with DIN 17440. The maximum allowed pressure is 1600 bar!
⁷ According to EN 837, maximum possible pressure is 1000 bar!

This data sheet contains product specification. Properties are not guaranteed. Subject to change without notice.

Ordering code DMP 334

21.7.2022

DMP 334

□	□	□	-	□	□	□	-	□	-	□	□	□	-	□	□	□	-	□	□	□
---	---	---	---	---	---	---	---	---	---	---	---	---	---	---	---	---	---	---	---	---

Pressure																						
Gauge		1	4	0																		
Input [bar]																						
0 ... 600 ¹					6	0	0	3														
0 ... 1000					1	0	0	4														
0 ... 1600					1	6	0	4														
0 ... 2000					2	0	0	4														
0 ... 2200					2	2	0	4														
Customer					9	9	9	9														
Output																						
4 ... 20 mA / 2-wire									1													
0 ... 20 mA / 3-wire									2													
0 ... 10 V / 3-wire									3													
Intrinsic safety Ex ia 4 ... 20 mA / 2-wire									E													
Customer									9													
Accuracy																						
0,35 % (standard)									3													
0,35 % including Calibration Certificate									S													
Table of measured values for accuracy 0,35 %									M													
Customer									9													
Electrical connection																						
Connector DIN 43650 (ISO 4400) (IP 65)									1	0	0											
Connector Binder 723 5-pin (IP 67)									2	0	0											
Cable gland PG7 / cable length specify (IP 67)									4	0	0											
+ PVC cable / 1 m																						
Connector Buccaneer (IP 68)									5	0	0											
Field housing stainless steel, cable gland M16 x 1,5 (IP 67)									8	0	0											
Connector DIN 43650 (ISO 4400) - potting compound inside (IP 67)									E	0	0											
Connector M12 x 1, 4-pin (IP 67)									M	0	0											
Connector M12 x 1, 4-pin (IP 67) - metal									M	1	0											
Cable outlet, cable with ventilation tube (IP 68)									T	R	0											
+ PVC cable / 1 m																						
Customer									9	9	9											
Mechanical connection																						
G 1/2" EN 837 (P _N ≤ 1000 bar) ²									2	0	0											
G 1/4" DIN 837 (P _N ≤ 1000 bar)									4	0	0											
M 16 x 1,5 internal thread									P	0	0											
M 20 x 1,5 internal thread									D	2	8											
9/16 UNF internal thread									V	0	0											
Customer									9	9	9											
Seals																						
Without seals - welded																			2			
Customer																			9			
Special version																						
Adjustable (using trimmers) - ATTENTION must not be used in an EX environment																				0	4	1
IS version, cable outlet, field housing																				0	0	0
Customer																				9	9	9

0,-... without additional charge / On request ... in accordance with the producer
 Surcharges for calibration are not subject to any discounts. Subject to change. □
 This document contains the specification for ordering the product;
 detailed technical parameters of the product and its possible variants are given in the data sheet.
 BD SENSORS reserves the right to change sensor specifications without further notice.

1 only available with pressure port G1/2" EN 837



BD SENSORS s.r.o.
 Hradištská 817
 CZ – 687 08 Buchlovice

Tel.: +420 572 411 011
 Fax: +420 572 411 497

www.bdsensors.cz
 info@bdsensors.cz

The company BD SENSORS s.r.o. is certified by TÜV SÜD Czech according to the standard ISO 9001.



2 According to EN 837, the pressure port and the complement, at pressure over 1000 bar must be preferably made of stainless steel with a tensile strength of $RP > 260 \text{ N/mm}^2$ in accordance with DIN 17440. The maximum allowed pressure is 1600 bar!



BD SENSORS s.r.o.
Hradištská 817
CZ – 687 08 Buchlovice

Tel.: +420 572 411 011
Fax: +420 572 411 497

www.bdsensors.cz
info@bdsensors.cz

The company BD SENSORS s.r.o. is certified by TÜV SÜD Czech according to the standard ISO 9001.

